

Merlin[®] WINGMATE 3

Articulated Swing Gate Opener
For gates up to 3 meters

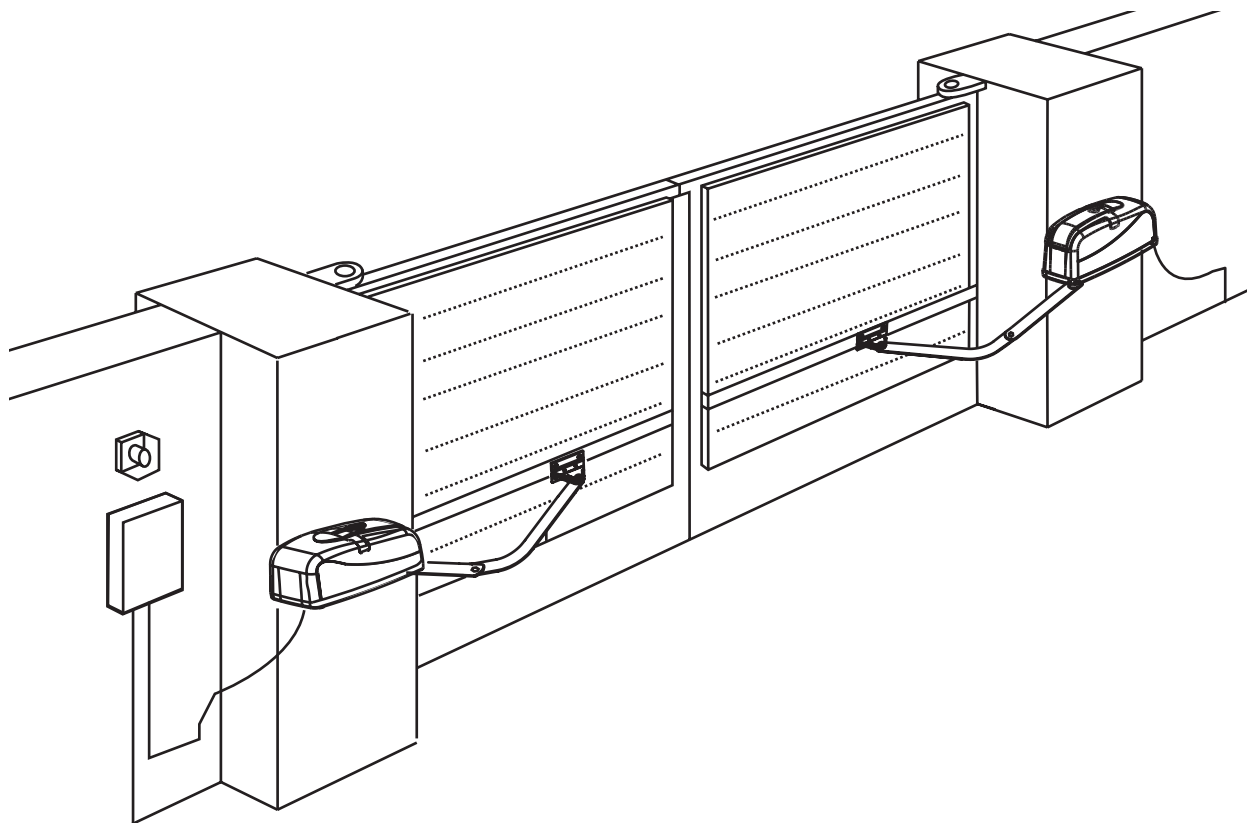

Installation and operation instructions
for MGA600 ARTICULATED Gate Motor.

**DESIGNED FOR PROFESSIONAL INSTALLATION
ONLY**

Chamberlain Australia Pty Ltd
PO Box 1446
Lane Cove NSW 1595
Phone Toll Free 1800 638 234

Chamberlain New Zealand Ltd
PO Box 100-221
North Shore 0745
Phone Toll Free 0800 653 667

www.go-merlin.com

Owners Copy: Please keep these instructions for future reference

WARNING

IMPORTANT ADVICE: THESE INSTRUCTIONS ESSENTIALLY DESCRIBE THE INSTALLATION OF THE MGA600 DRIVE WITH THE ACCESSORY ARM ART-3, FOR INSTALLATION ON A SWING GATE
IF THE ART-1 FOLDING GATE ARM OR THE SPACE-SAVING ART-2 GATE ARM ARE INSTALLED IT IS ESSENTIAL TO FOLLOW THE INSTRUCTIONS INCLUDED WITH THOSE ITEMS. THE INSTALLATION WORK VARIES FROM THESE INSTRUCTIONS AT SOME POINTS. WARNING AND SAFETY ADVICE IS EXCEPTED FROM THIS.

PLEASE START BY READING THESE IMPORTANT SAFETY RULES



This safety alert symbol means "Caution" - failure to comply with such an instruction involves risk of personal injury or damage to property. Please read these warnings carefully.

This gate drive mechanism is designed and tested to offer appropriately safe service provided it is installed and operated in strict accordance with the following safety rules.

Incorrect installation and/or failure to comply with the following instructions may result in serious personal injury or property damage.



Do not wear rings, watches or loose clothing while servicing or installing a gate opener.



Installation and wiring must be in compliance with your local building and electrical installation codes. Power cables must only be connected to a properly earthed supply.



Entrapment between the moving gate and walls due to the opening movement must be avoided by using safety edges or IR sensors when necessary.



Please remove any locks fitted to the gate in order to prevent damage to the gate. A special E-Lock is available as accessory.



After installation, ensure that the gate opener system is properly adjusted and that the safety system and the manual release function correctly.



This drive **must not** be used with a gate incorporating a wicket door.



The actuating member of a biased-off switch, if installed, is to be located within direct sight of the gate but away from moving parts. Unless it is key operated, it is to be installed at a minimum height of 1.5m and not accessible to the public.



It is important to make sure that the gate always runs smoothly. Gates which stick or jam must be repaired immediately. Employ a qualified technician to repair the gate, never attempt to repair it yourself.



Keep additional accessories away from children. Do not allow children to play with any controls. Keep remote controls away from children. Operate gate when it is in full view and no one is near the gate. A gate can cause serious injuries or death as it opens or closes.



Connect the gate opener to a properly **EARTHED** general purpose 240 V mains power outlet installed by a qualified electrical contractor.



DISCONNECT THE POWER CORD from the mains power before making any repairs or removing covers. Only **EXPERIENCED** service personnel should remove covers from the gate opener.



Make sure that people who install, maintain or operate the gate drive follow these instructions. Keep these instructions in a safe place so that you can refer to them quickly when you need to.



The gate drive system is to be regularly examined for any signs of wear and tear or damage. The gate drive system must not be used if repair or adjustments are needed.

BEFORE YOU BEGIN

The MGA is suitable for use with wide pillars, up to about 30cm in width. The maximum recommended opening angle of the gate is 125 degrees. Ensure that ample space is available next to the drive for the arms and assembly. Gates exposed to a high wind load must be fixed with an electric lock for additional protection. While the drive is fitted with internal limit switches, stops should also be mounted on the ground to prevent gate rattle or flutter. There are many factors to consider when choosing the right drive mechanism. Assuming that a gate functions properly, "startup" is the most difficult phase, once the gate is in motion, significantly less force is usually required to move it.

- **Gate size:** The gate size for this drive must not be more than 3.0m. Wind can brake or distort the gate, thereby increasing the amount of force needed to move it considerably.
- **Gate weight:** The weight of the gate must not be more than 250kg.
- **Effect of temperature:** Be sure that the ambient temperature where the drive is installed will be between -20 to +55C° deg since low outdoor temperature can prevent the motor from starting. High outdoor temperatures along with frequent use can cause the motor thermal protection to operate. Wait 15 minutes if this has occurred.

TABLE OF CONTENTS

WARNINGS

Warnings and Precautions1
 Carton Inventory2

GATE MOTOR INSTALLATION

Installation Checklist3
 Gate Types3
 Gate Motor Installation4-6
 Manual Release5

CONTROL BOARD INSTALLATION

Warnings6
 Safety Installation Information7
 Control Board Specifications8
 Cable Requirements8
 Mount The Control Box9-10
 Wiring Single Motor To Control Board11-12
 Wiring Dual Motors To Control Board13-14
 Installation of Safety IR Beams15

BASIC CONTROL BOARD SETUP

BiPart Delay14
 Connecting Control board to GPO16
 Connecting Batteries17
 Setting the CAMS18
 Programming19-20
 Force Setting/Timer to Close/Party mode21
 Program Remote Control Transmitters22

OPERATION and MAINTENANCE

Operation of your Gate Opener23
 Wiring Diagram24
 Control Inputs25
 Diagnostics26
 Troubleshooting27-29
 Spares30
 Warranty31

CARTON CONTENTS

MGA600M Carton Contents (Master Kit):

1. MGA x1
2. CB12ANZ (Control Board)
3. ART-3AL x1
4. ART-7 (041AART-0007) x1
5. Battery (MER150) to suit CB12ANZ x1
6. Transmitters C945 x2
7. 772ANZ IR Beams x1

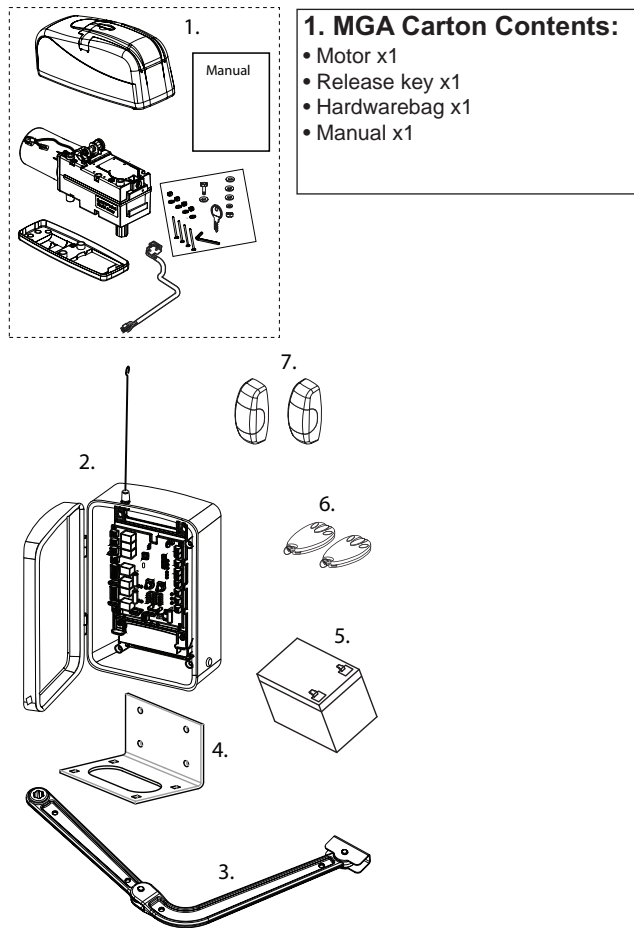

MGA600S Carton Contents (Slave Kit):

1. MGA x1
2. ART-3AL x1
3. ART-7 (041AART-0007) x1
4. Battery (MER150) to suit CB12ANZ x1
5. JB12M (LA400-JB40 kit) x1

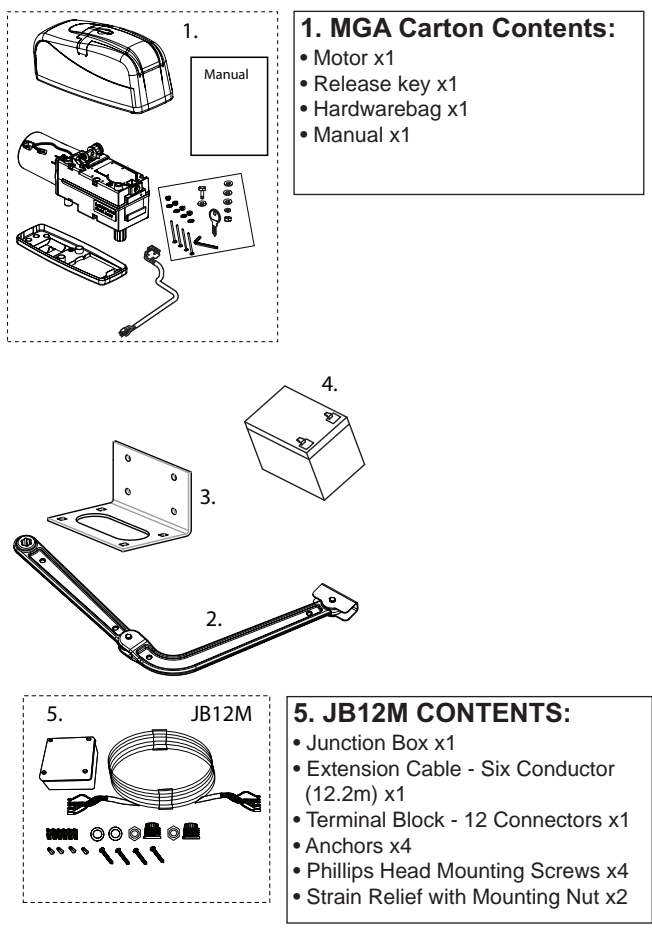

INSTALLATION CHECKLIST - PREPARATIONS

Check the carton contents and read the instructions carefully. Make sure your gate equipment operates perfectly. The gate must run evenly and smoothly and must not stick at any point. Remember that the ground level may be several centimeters higher in winter. The gate must be stable and as free of backlash as possible in order to prevent any unwanted to and fro movement. The more smoothly the gate leaf runs, the more sensitive the force adjustment must be.

Note down any materials you still need and obtain them before starting to install. Heavy-duty plugs, bolts, gate stops, cables, distribution boxes, tools, etc.

GATE TYPES

The gate type determines the location where the drive mechanism is installed. If the gate stop is on the ground, the drive mechanism must also be installed at a height that is as low as possible so that it cannot twist the gate. Use only parts of the gate frame for fixing purposes.

For steel gates, the gate fitting must be attached to the main frame. If you are uncertain whether the available support is sufficiently stable, reinforce it.

In the case of wooden gates, the gate fitting must be through bolted. It is advisable to fit a plate from the outside so that the fixing brackets cannot become loose over time. Thin wooden gates must also be reinforced in order to withstand the stresses encountered.

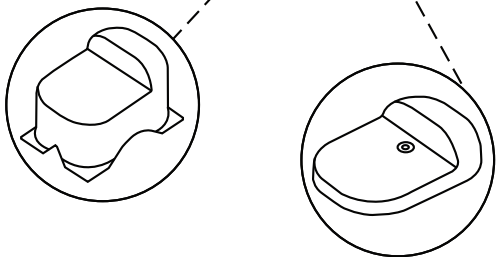
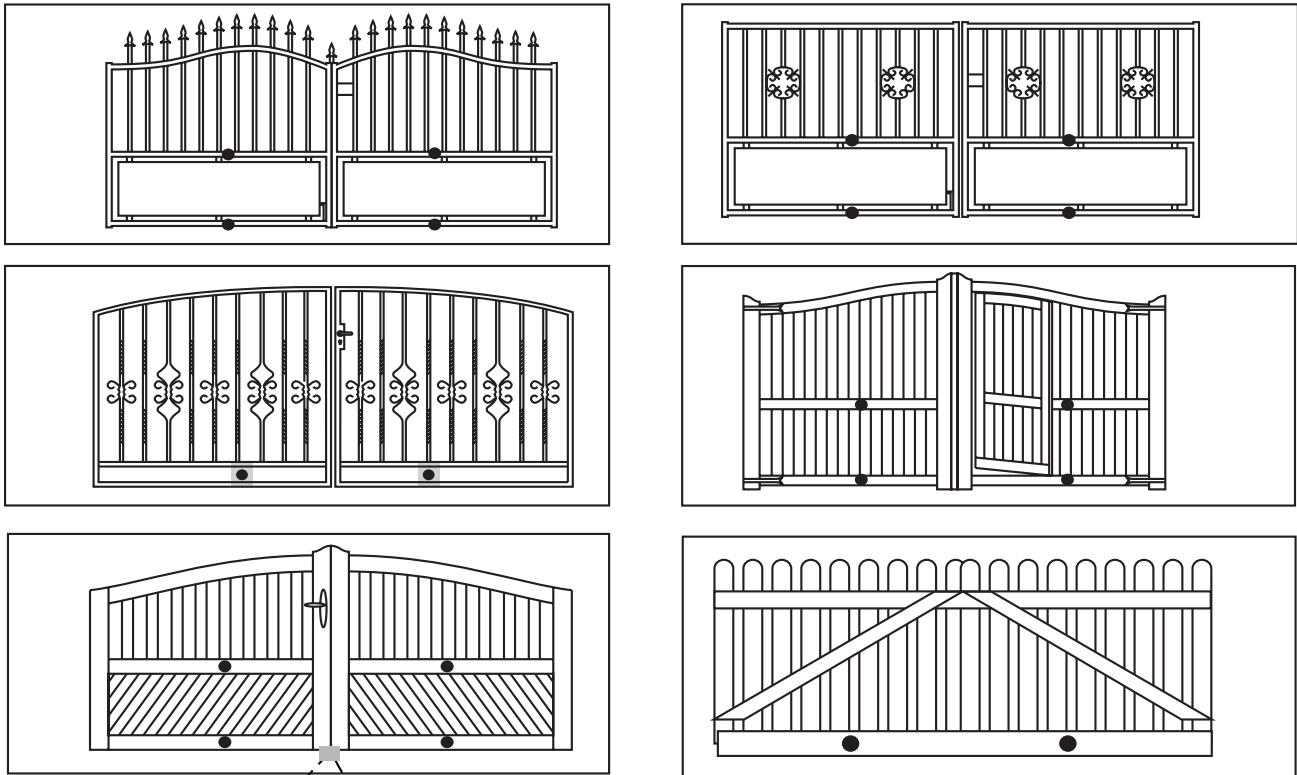

FOR TWO GATE APPLICATION A FIXED GATE STOP MUST BE INSTALLED.

Gate stops save wear and tear on the drive mechanism, gate and fittings. Operating a gate without fixed limit stops results in poor performance. It is often dangerous, leads to premature wear in the case of heavy gates often exposed to wind stress.

MOUNTING REQUIREMENTS

The gate drive mechanism is suitable for use in conjunction with pillars with a max. thickness of 30cm. The amount of room around the pier affects the opening angle and the position of the arms. The drive mechanism is equipped with built-in limit stops for both the OPEN and CLOSE directions. A different opening angle can be set for the left-hand wing as compared with the right-hand one.

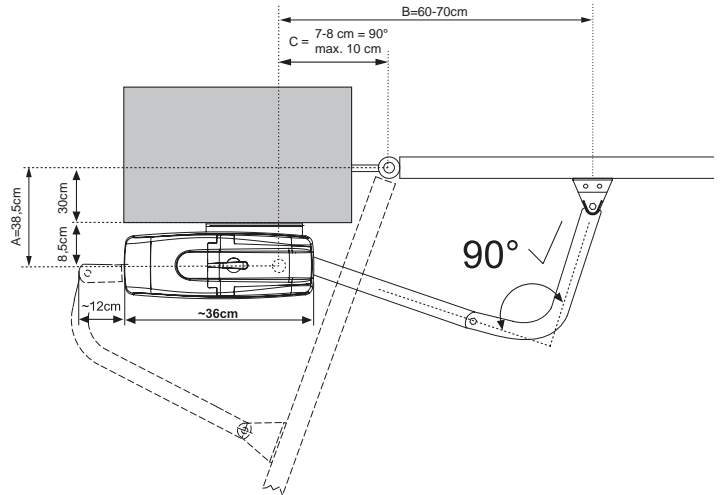

INSTALLATION

Step 1 Install Motor Bracket

For Stone or reinforce concrete pillars use Dynabolts or Chemical anchors (not supplied) to mount the motor support bracket onto the wall at the desired height. The gate motor exerts a considerable force, ensure the wall is suitable. It may be necessary to use metal reinforcing, if so weld the bracket onto the brace to prevent damage to the wall and or motor.

If fastening to brickwork CHEMICAL ANCHORS should be used and metal reinforcing is highly recommended.

DO NOT USE PLASTIC ANCHOR TO MOUNT THE BRACKET IN PLACE.

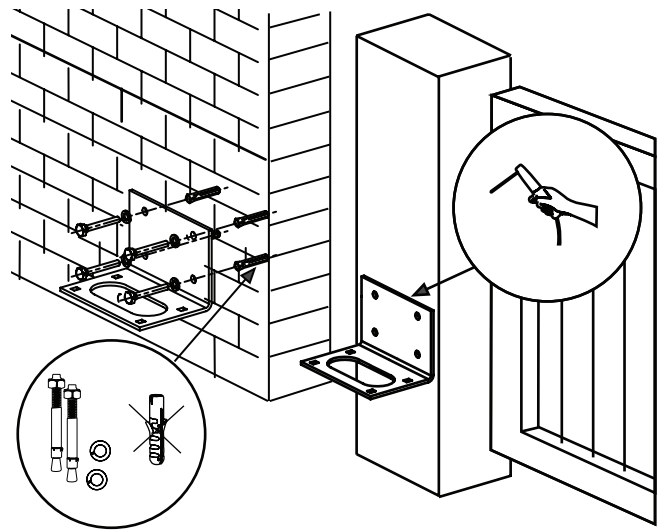

Step 2 Prepare the Motor Housing

Taking note of the the Motor's orientation, carefully knock out one of the four tap in the base housing as illustrated to allow for cable entry. Several openings for the cable have been pre-punched in the base and need only be broken through. Place the base plate onto a solid surface whilst breaking the holes through to prevent the PVC base plate from breaking. A small, flat screwdriver should be used for breaking the holes through. For this purpose, tap on the screwdriver handle with the palm of the hand from the inside. Repeat this as necessary at several points on the pre-marked circle. The pre-punched area can then be easily removed and the strain relief supplied as standard fitted in its place.

Thread the Terminated Loom through the gland nut and into the hole knocked out for cable entry. Thread the gland over the cable and through the knockout hole as illustrated. Fasten the Gland in place firmly with the nut. Hand tighten the bottom nut, allowing around 200mm of cable to protrude.

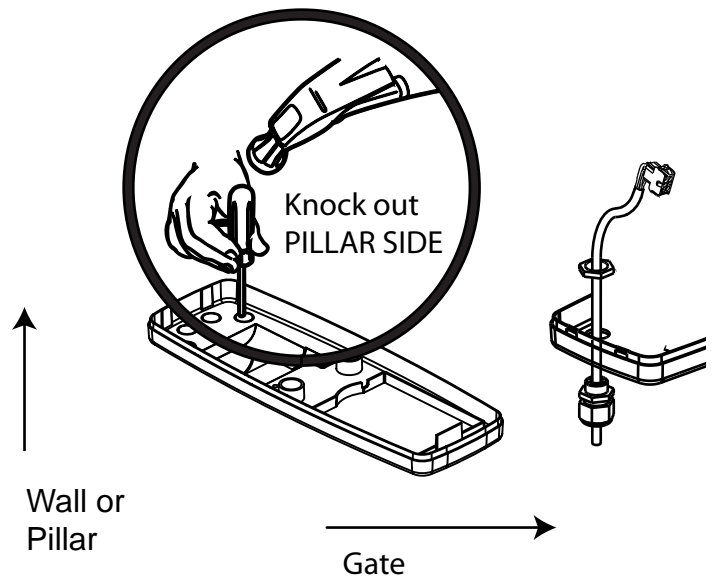

Step 3 Mounting the motor to the Wall Bracket.

Once the Wall Bracket has been mounted, the drive can be fitted. The drives can be used left or right without conversion.

Using the hardware provided fit the Base Plate onto the Wall Bracket. Place the Spacer provided into place as illustrated, then insert the bolts provide through the square hole in the Wall Bracket.

Ensure the connection cable is correctly positioned, and the bolts are fitted correctly. Hand tighten the nuts to secure the motor in position, then using the washers and nuts provided to fasten the motor securely in place using 13mm spanner (not provided).

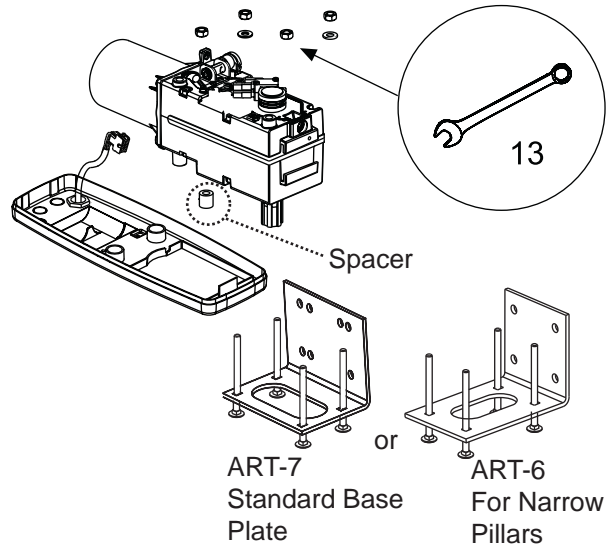

Step 4 Connect Motor to Loom.

Connect the Connection Cable in the motor as illustrated (fig1).

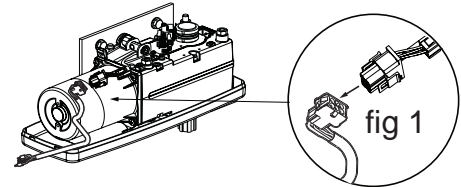

Step 5 Manual Release.

The release lock for the casing is located under the rubber waterproof cover. Use the socket spanner supplied in the hardware bag to lift the cover up. The release key located beneath the hood should be inserted into the side openings and turned approx. 180 degrees until it cannot turn any further. The drive has now been released. To re-engage it, the key should be turned back to its original position.

NOTE: Take care when unlatching the drive for manual operation. The gate panel can move in an uncontrolled way, especially if it is mounted in a sloped position.

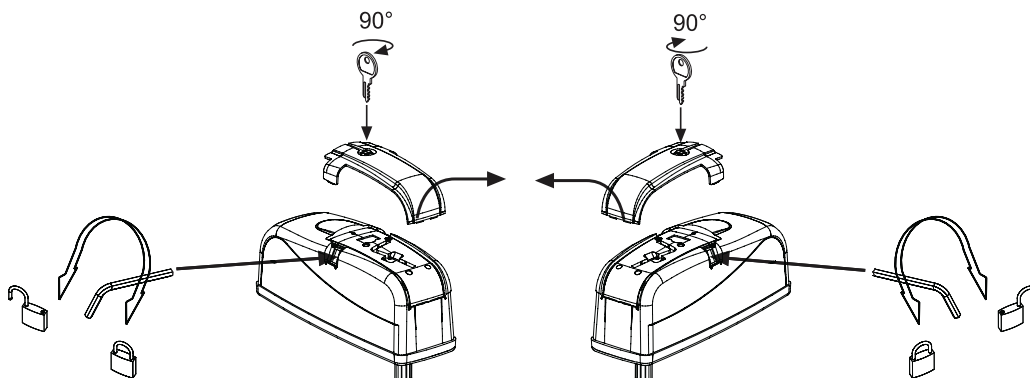

Step 6 Fit the Gate Arm.

Use the Release Key provided in your hardware bag to Disengage the Motor by turning the Hex head nut located on the top of the motor.

Assemble your Gate Arm and fasten in place using the bolt and washer provided.

The Gate Arm exerts considerable forces on the gate and all fixings. For this reason the Gate Arm **MUST BE FASTENED SECURELY** to the gate frame. Where possible Weld the bracket in place for metal gates. For Timber gates through bolts should be used.

Use the Mounting Requirments outlined below for mount- ing requirements and bracket locations.

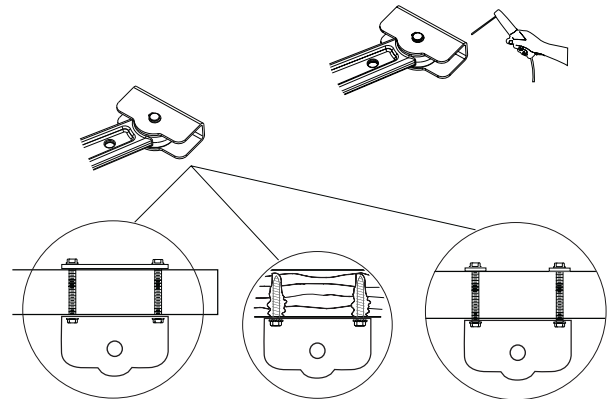
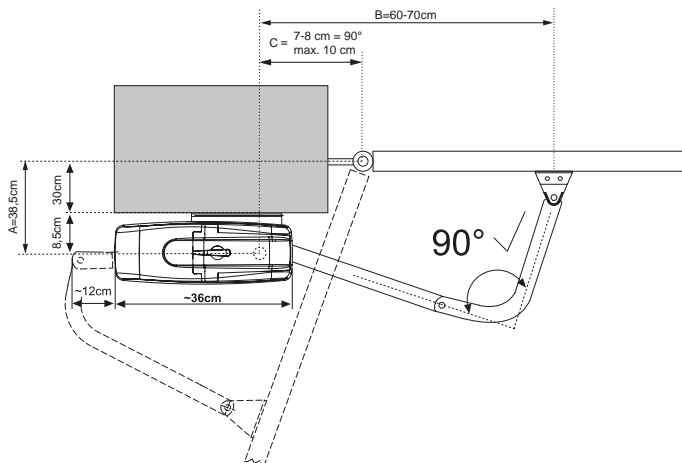
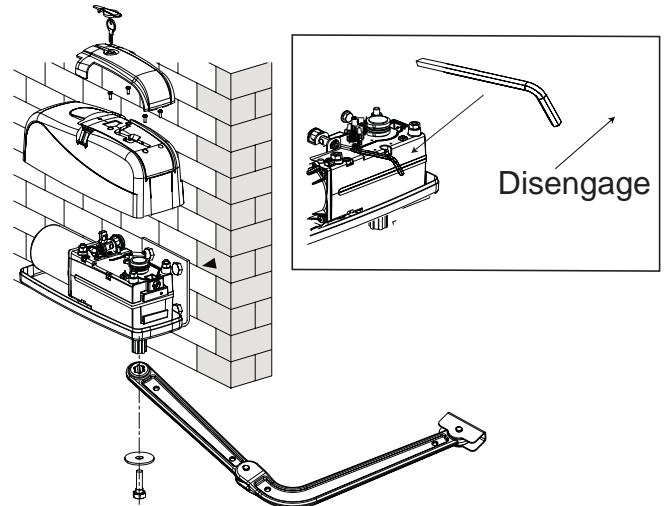

INSTALLATION

SAFETY PRECAUTIONS FOR SWING and ORNAMENTAL "GRILL TYPE GATES"

⚠ WARNING

To prevent **SERIOUS INJURY** or **DEATH** from a moving gate:

- Entrapment protection devices **MUST** be installed to protect anyone who may come near a moving gate.
- Locate entrapment protection devices to protect in **BOTH** the open and close gate cycles.
- Locate entrapment protection devices to protect between moving gate and **RIGID** objects, such as posts.
- A swinging gate shall **NOT** open into public access ways.

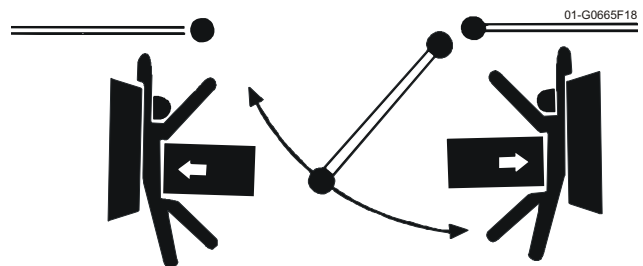

NOTE: It is recommended an E-lock or Maglock be used on gates over 2m for added security against vandalism and adverse weather.

SAFETY INSTALLATION INFORMATION

Warning - To reduce the risk of SEVERE INJURY or DEATH from an incorrect installation:

1. Vehicular gate systems provide convenience and security. Gate systems are comprised of many component parts. The gate operator is only one component. Each gate system is specifically designed for an individual application.
2. Gate operating system designers, installers and users must take into account the possible hazards associated with each individual component. Poorly designed, installed or maintained gate systems may be dangerous to users and bystanders. Gate installers and designers should therefore take steps to reduce the public's exposure to potential hazards.
3. A gate operator can generate a great deal of force during operation, installers must be mindful of this fact. Safety features must be incorporated into every design. Specific safety features include:
 - Gate Edges
 - Vertical Posts
 - Guards for exposed rollers
 - Instructional and Precautionary Signage
 - Photoelectric Sensors
4. A gate opener should only be installed where:
 - a. The operator is appropriate for the construction and the usage class of the gate.
 - b. All exposed pinch points are eliminated or guarded, and guarding is supplied for exposed rollers.
5. The operator is intended for installation only on vehicular gates only, pedestrians should be supplied with a separate access
6. The gate must be installed in a location so that enough clearance is supplied between the gate and adjacent structures when opening and closing to reduce the risk of entrapment. Swinging gates shall not open into public access areas.
7. The gate must be properly installed and work freely in both directions prior to the installation of the gate operator.
8. Controls must be far enough from the gate so that the user is prevented from coming in contact with the gate while operating the controls.
9. Any warning signs must be clearly visible, on each side of the gate.
10. For a gate operator utilising a non-contact sensor:
 - a. Reference owner's manual regarding placement of non-contact sensor for each type of application.
 - b. Care shall be exercised to reduce the risk of nuisance tripping, such as when a vehicle trips the sensor while the gate is still moving.
 - c. One or more non-contact sensors shall be located where the risk of entrapment or obstruction exists, such as the perimeter reachable by a moving gate or barrier.
11. For a gate operator utilizing a contact sensor such as an edge sensor:
 - a. A hard wired contact sensor shall be located and its wiring arranged so the communication between the sensor and the gate operator is not subject to mechanical damage.
 - b. A wireless contact sensor such as the one that transmits radio frequency (RF) signals to the gate operator for entrapment protection functions shall be located where the transmission of the signals are not obstructed or impeded by building structures, natural landscaping or similar obstruction. A wireless contact sensor shall function under the intended end-use conditions.
 - c. One or more contact sensors shall be located at the leading edge, trailing edge and post mounted both inside and outside of a vehicular horizontal slide gate.
 - d. One or more contact sensors shall be located at the bottom edge of a vehicular vertical lift gate.
 - e. One or more contact sensors shall be located on the inside and outside leading edge of a swing gate. Additionally, if the bottom edge of a swing gate is greater than 15cm (6") above the ground at any point in its arc of travel, one or more contact sensors shall be located on the bottom edge.

IMPORTANT SAFE OPERATING/MAINTENANCE INSTRUCTIONS

WARNING

To reduce the risk of SEVERE INJURY or DEATH:

1. READ AND FOLLOW ALL INSTRUCTIONS.
2. NEVER allow children to operate or play with gate controls. Keep the remote control away from children.
3. ALWAYS keep people and objects away from the gate. NO ONE SHOULD CROSS THE PATH OF THE MOVING GATE.
4. Test the gate operator monthly. The gate MUST reverse on contact with a rigid object or stop when an object activates the non-contact sensors. After adjusting the force or the limit of travel, retest the gate operator. Failure to adjust and retest the gate operator properly can increase the risk of INJURY or DEATH.
5. Use the manual release ONLY when the gate is not moving.
6. KEEP GATES PROPERLY MAINTAINED. Read the owner's manual. Have a qualified service person make repairs to gate hardware.
7. The entrance is for vehicles ONLY. Pedestrians MUST use separate entrance.
8. This appliance is not intended for use by persons (including children) with reduced physical sensory or mental capabilities, or lack of experience and knowledge, unless they have been given supervision or instruction concerning use of the appliance by a person responsible for their safety.

CARTON INVENTORY

CB12ANZ CONTROL BOARD KIT
 1x PVC – Box
 1x CB12-Logic Board (pre-mount)
 1x Charge transformer (pre-mount)
 1x Antenna

SPECIFICATION

Main Output (Motor) 12vdc Battery run, Operational between 11vdc and 14vdc.
Accessory power 12vdc nominal Class II battery (500ma max length conversion)
Power Consumption 30 Watts max (during battery Charging).
Temperature -20°C to +50°C

Protection Fuse Battery 1 ATC20A
Protection Fuse Battery 2 ATC20A

CABLE SIZES

* Solar Powered Panels - The size of these depends on: the duty cycle of the gates; the hours of sun-light; and the number and type of accessories fitted. 30 watts is recommended for Residential use. The conductor size needs to be in accordance with **Table 1** below, as a minimum.

* Battery Powered with trickle charging - Due to the high cost of long runs of heavy cable, it may be more economical in some installations to operate the gates from a battery, which is charged from a remotely located trickle charger.

For example: a 15 VAC 2.5 Amp plug pack can be located at the house, with appropriate wiring to the gate, controller, and battery some distance away.

Follow **Table 1** for minimum recommended conductor sizes for different distances.

WIRING: All wiring must be arranged to prevent water entering the controller enclosure. Do not wire mains voltage and low voltage control wires in the same conduit.

* Low voltage motor cable sizes - Voltage will drop along low voltage cables over long distances. It is recommended to use cable with conductors of the following minimum cross sectional areas. **Table 2** lists lengths for twin-core cable, from a 12 V supply and 5 Amp load.

TABLE 1

Cable length	Conductor size mm ²	AWG#
Up to 30 m	1.5 mm ²	16
Up to 100 m	2.5 mm ²	14

TABLE 2 - Motor Cable

Cable length	Conductor size mm ²	AWG#
3 m	1.5 mm ²	16
5 m	2.5 mm ²	14
10 m	4 mm ²	12
15 m	6 mm ²	10
20 m	10 mm ²	8

Mount the Control Box

The control box MUST be mounted within 1.5m of the gate operator. Mount the control box as high as possible for best radio reception

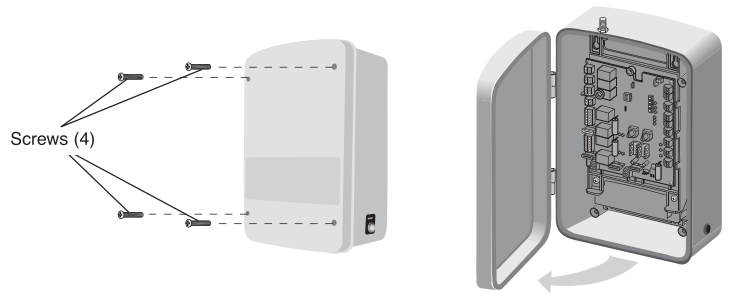

1. Open the Control Box

Remove the screws and open the box.

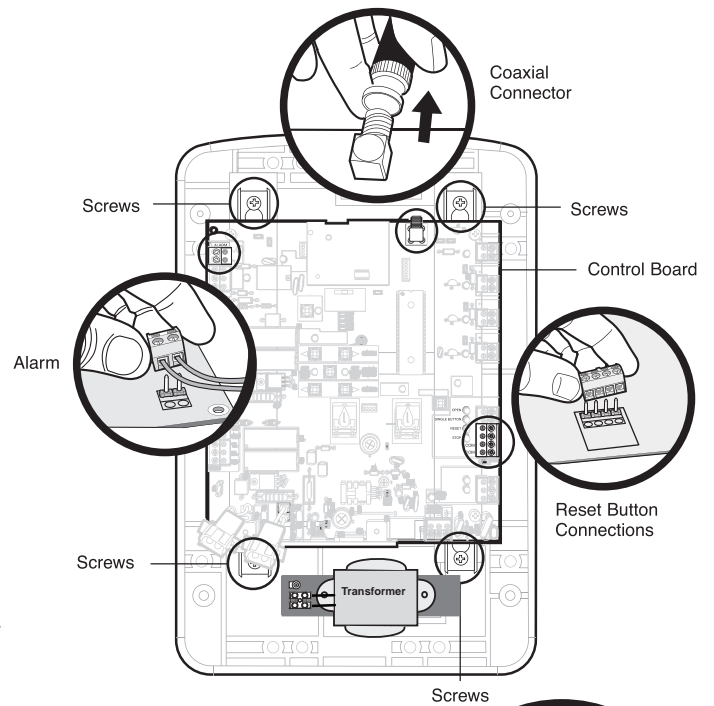

2. Remove the Control Board

Disconnect reset button, alarm and internal coaxial connector. Loosen screws and remove Control Board. Set aside IR beams, remotes, antenna, hardware bag* and battery looms.

*Hardware bag includes, cable glands, fixing screws, replacement fuse and three wire nuts.

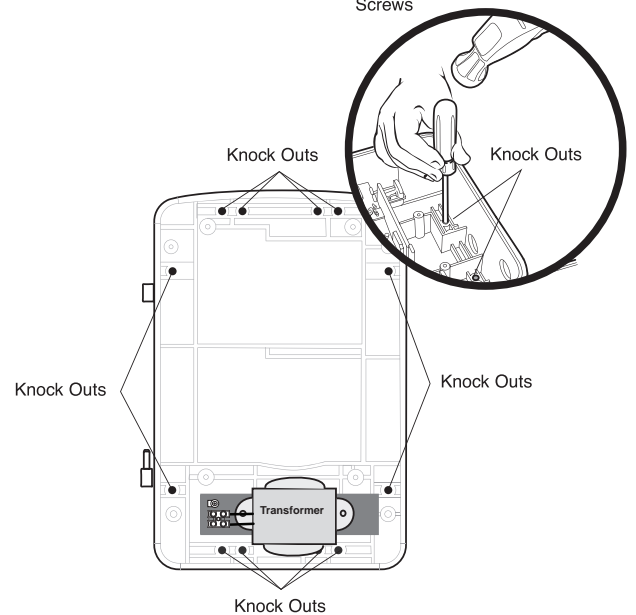

3. Select Mounting Holes

Select holes to be used for mounting and knock out using a screw driver and hammer.

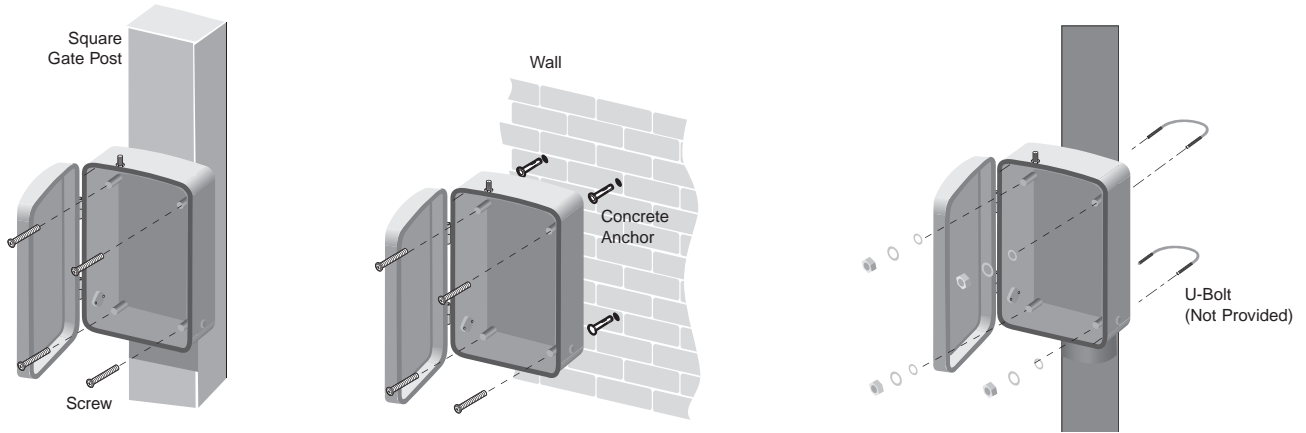

4. MOUNT THE CONTROL BOX

Secure the control box to mounting surface (post, wall, column, etc.) using the four fixing screws provided. If fixing to masonry or tube steel you will require additional hardware (not provided).

IMPORTANT NOTE:
Waterproof all knockout holes using silicon sealant.

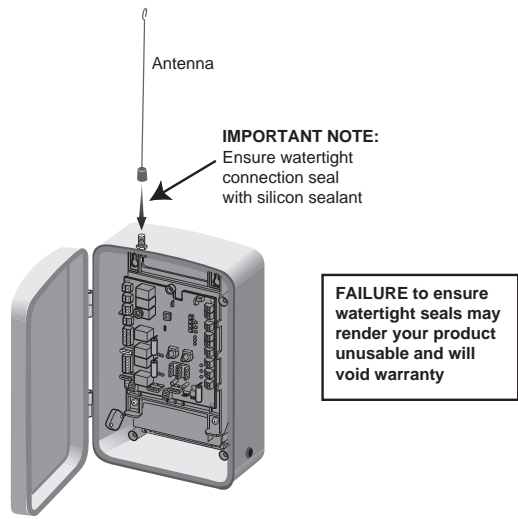
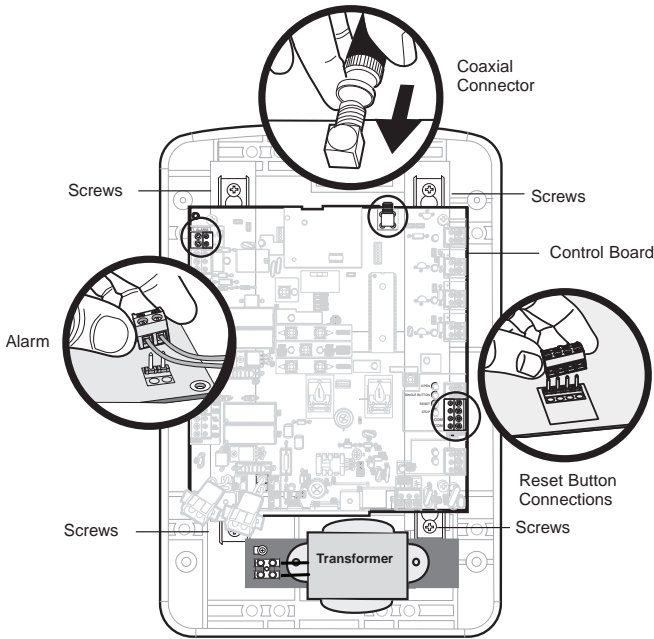

FAILURE to ensure watertight seals may render your product unusable and will void warranty

5. INSTALL THE BATTERY/BATTERIES AND CONTROL BOARD

Attach antenna. Install batteries and connect battery looms. Reinstall control board, alarm, and reset button. Re-connect internal coaxial connector.

NOTE: Make sure battery leads are on the left side of the control box and not pinched.
Do **NOT** connect battery looms to the control board at this time.

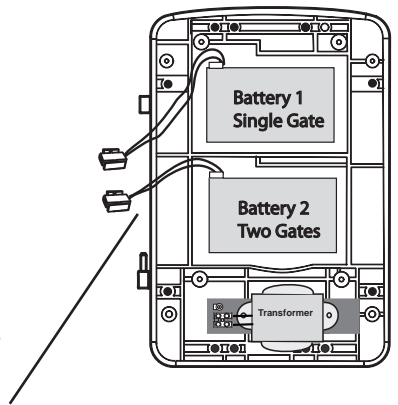

NOTE: Before proceeding to the next page, please ensure gate motors are installed.

WIRING

WARNING

Please observe the WARNINGS outlined on Pages 1 and 7 of this manual.

Connect Gate Operator (Gate 1) to Control Box

1 WATERTIGHT CONNECTOR NUT

Insert operator cable through watertight connector nut.

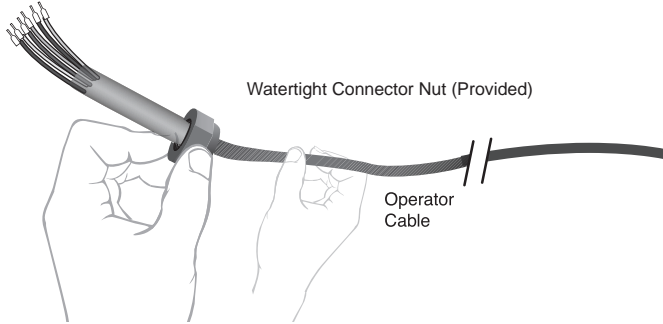

2 INSERT OPERATOR CABLE

Insert watertight connector into the bottom of the control box and tighten with nut. Insert operator cable through watertight connector mounted in the bottom of the control box.

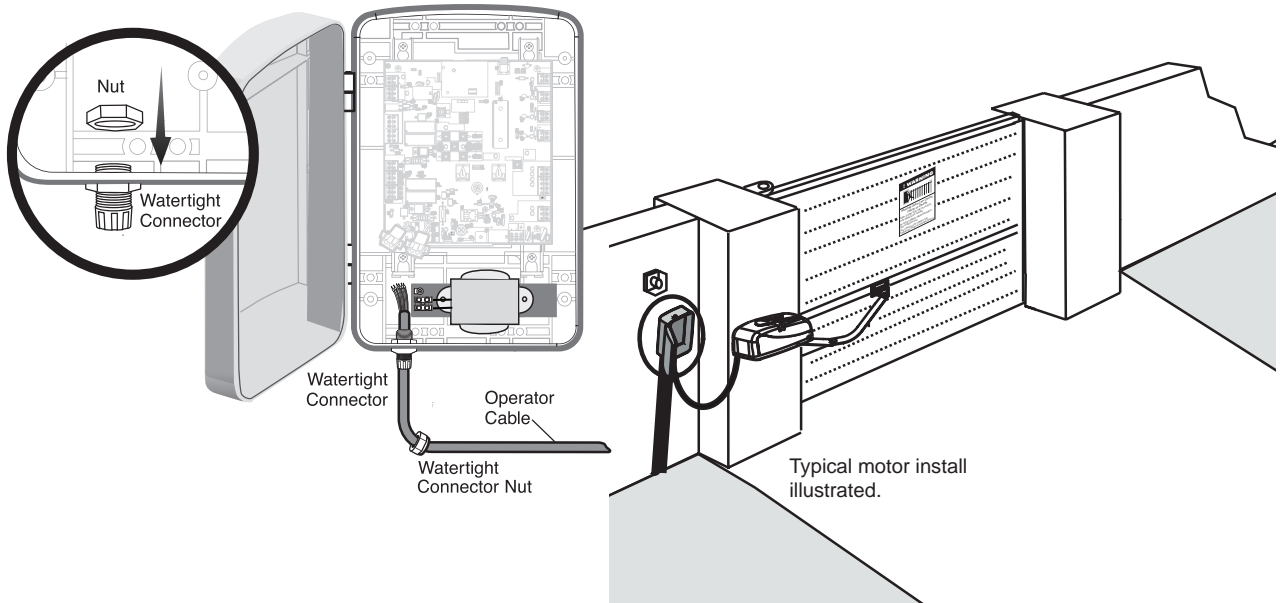

3. CONNECT OPERATOR TO CONTROL BOARD

Extend operator cable and wires to GATE 1 connector and connect as shown. Tighten watertight connector nut.

IF INSTALLING ONE OPERATOR, PROCEED TO PAGE 15.
If installing two operators, continue to the next page.

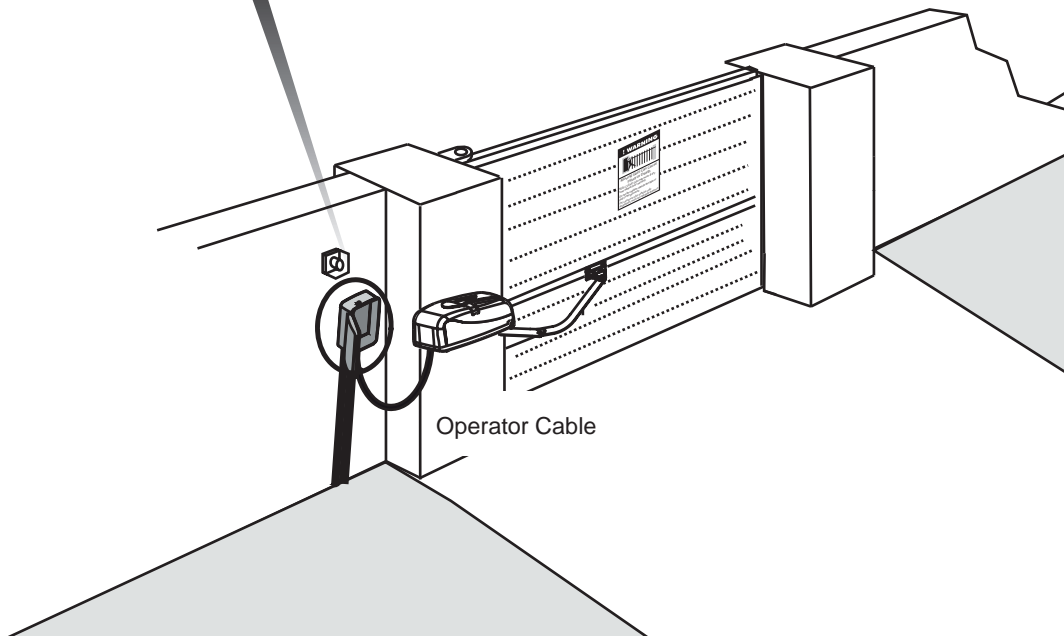
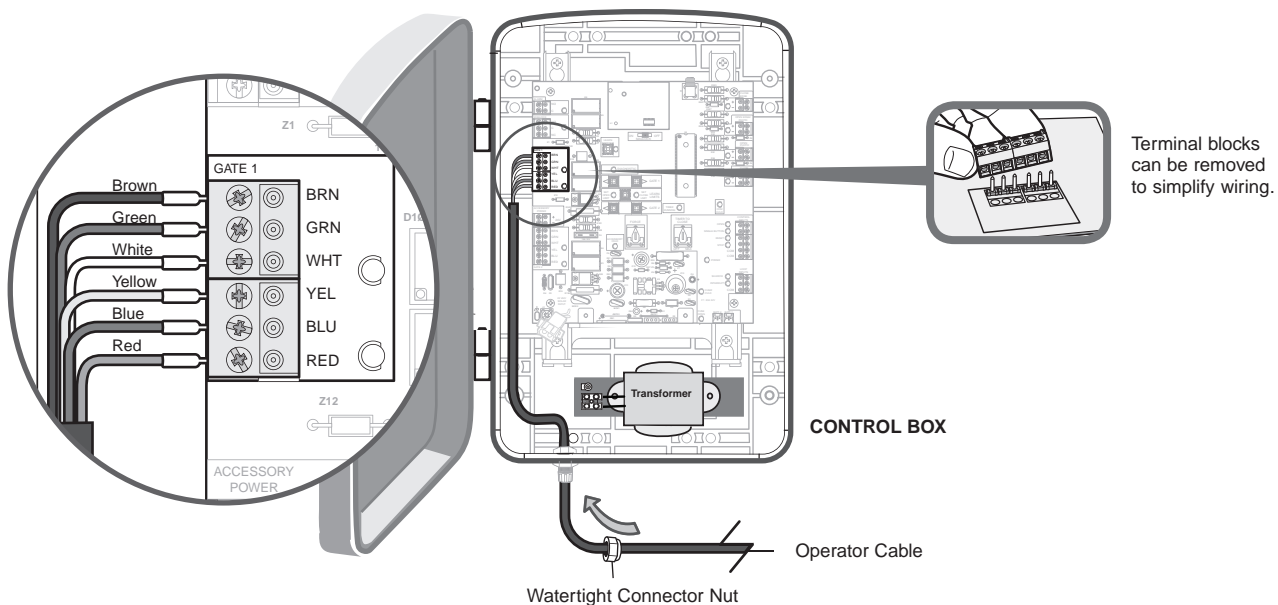

1. CONNECT SECOND OPERATOR TO CONTROL BOARD MGA600

NOTE: Junction box and extension kit part number JB12M is included in the slave kit (MGA600S) for this function.

- Before digging, contact local underground utility locating companies.
- Trench across driveway to bury the extension cable.
- Use PVC conduit to prevent damage to cables.
- Insert extension cable through watertight connector nut and through an available watertight connector mounted in the control box.
- Extend cable and wires to GATE 2 connector and connect as shown.
- Secure extension cable to control box using watertight connector nut.

FAILURE TO INSTALL THE SLAVE OPENER WITH CORRECT CABLE WILL VOID YOUR WARRANTY.

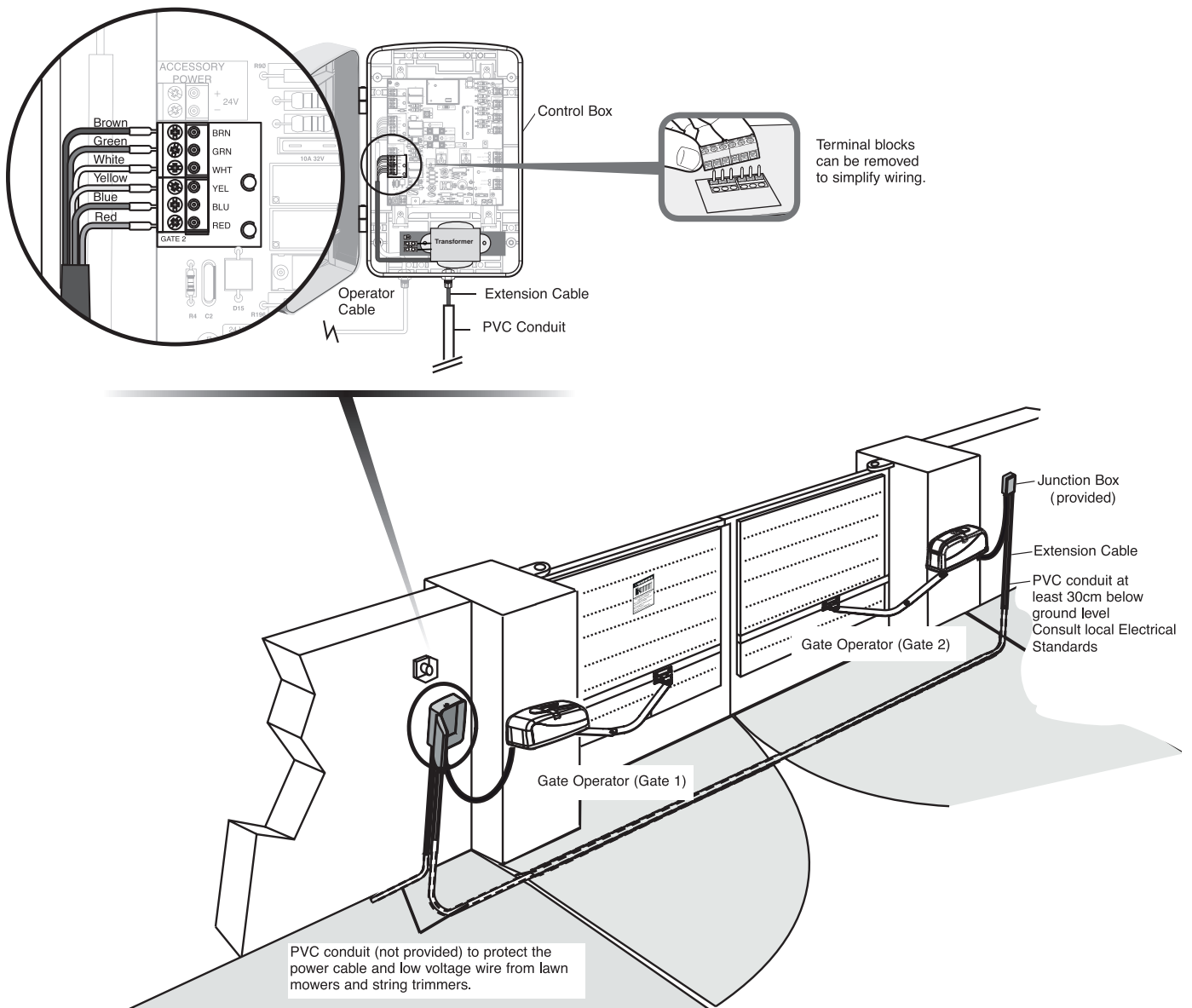

Connect Gate Operator (Gate 2) to Control Box

Occasionally in dual gate installations, one gate would need to open first and close second. This would happen if there was an ornamental overhang on one gate or if using a solenoid lock, for example. This gate is called the Primary gate and needs to be connected to Gate 1 connections on the control board. Thus, it is preferred that the control box be installed on the same side as this gate. If there is no appropriate location on that side for the control box, then mount the control box on the opposite side, but connect the operator closest to the control box to the Gate 2 connector and the operator on the opposite side to the Gate 1 connector.

SET THE LOCK/BIPART DELAY

The **LOCK/BIPART DELAY** switch on the control board needs to be set to the ON position.

The following illustration shows a dual gate configuration with a decorative overlapping piece on the outside of the gate.

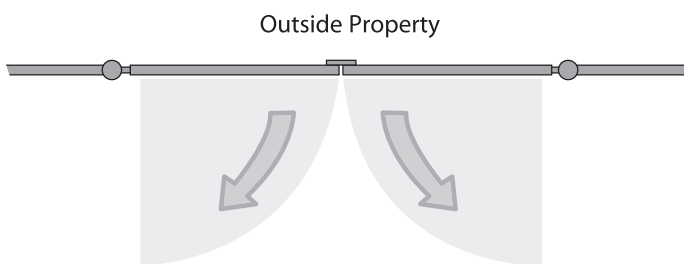

Primary Gate - Connect to Gate 1 Connector on Control Board.

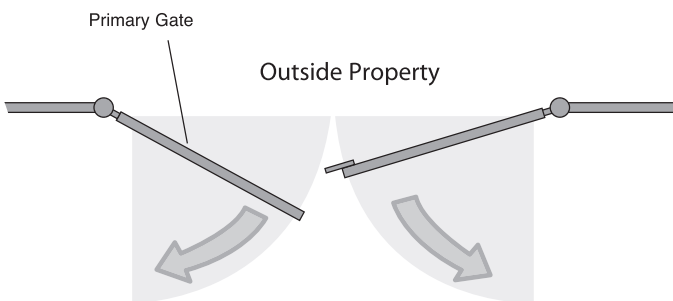

If a solenoid lock is being used on a gate, the gate with the lock attached to it would be the primary gate.

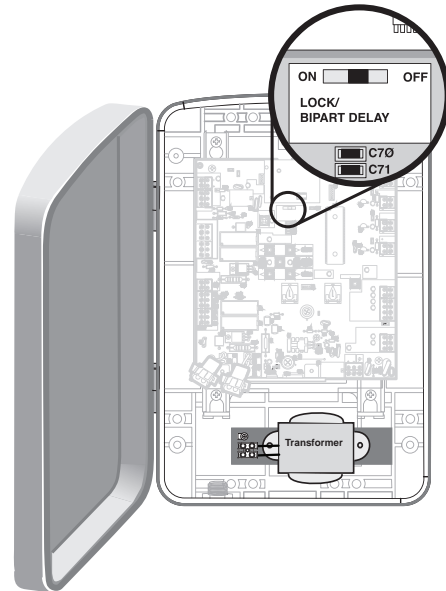

IR SAFETY BEAMS 772ANZ

IR Safety Beams are recommended to reduce the risk of personal injury and vehicle damage.

EN1243 specifies that IR Beams be installed at a height of 200 mm and activated to “close”.

The sensors consist of a transmitter and receiver installed opposite to each other across the gate access.

INSTALLATION

Install the beams opposite each other in the position required to maintain safe access, using small screws and wall plugs.

Using suitable cable, (2 wire) connect the beams to each other and to the control box Safety Sensor inputs (see wiring diagram page 24).

Use “open” photo and “Closed” photo as required.

PROGRAMMING of IR BEAMS

This is automatically achieved when programming the “Travel Limits” of the gate. See programming section.

IR BEAM DIAGNOSTIC LEDs

NOTE: Remove sensor covers to access.

LED ON = Power and alignment OK
LED FLASHING = Obstruction or misalignment
LED OFF = No power or sleep mode

TO DISABLE IR BEAMS - remove wires from the terminals and reset limits. See programming section.

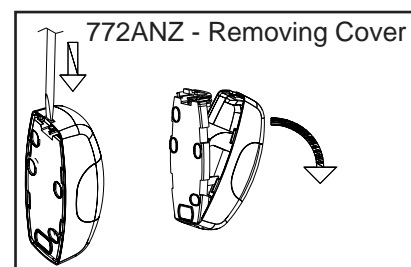
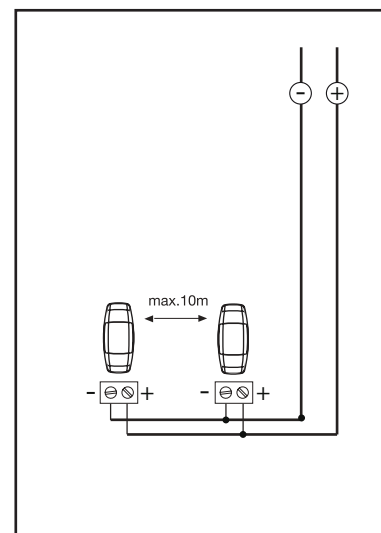

CONNECTING OPTIONAL SOLAR PANEL (NOT SUPPLIED)

If you are using a SOLAR PANEL, the Transformer **MUST** be unplugged and removed. Terminate the Solar Panel into the AC PWR/SOLAR Terminals as illustrated below.

NOTE: Solar Panel should be 12 Volt, up to 30 Watt with class 2 output. Two batteries are also recommended for solar systems.

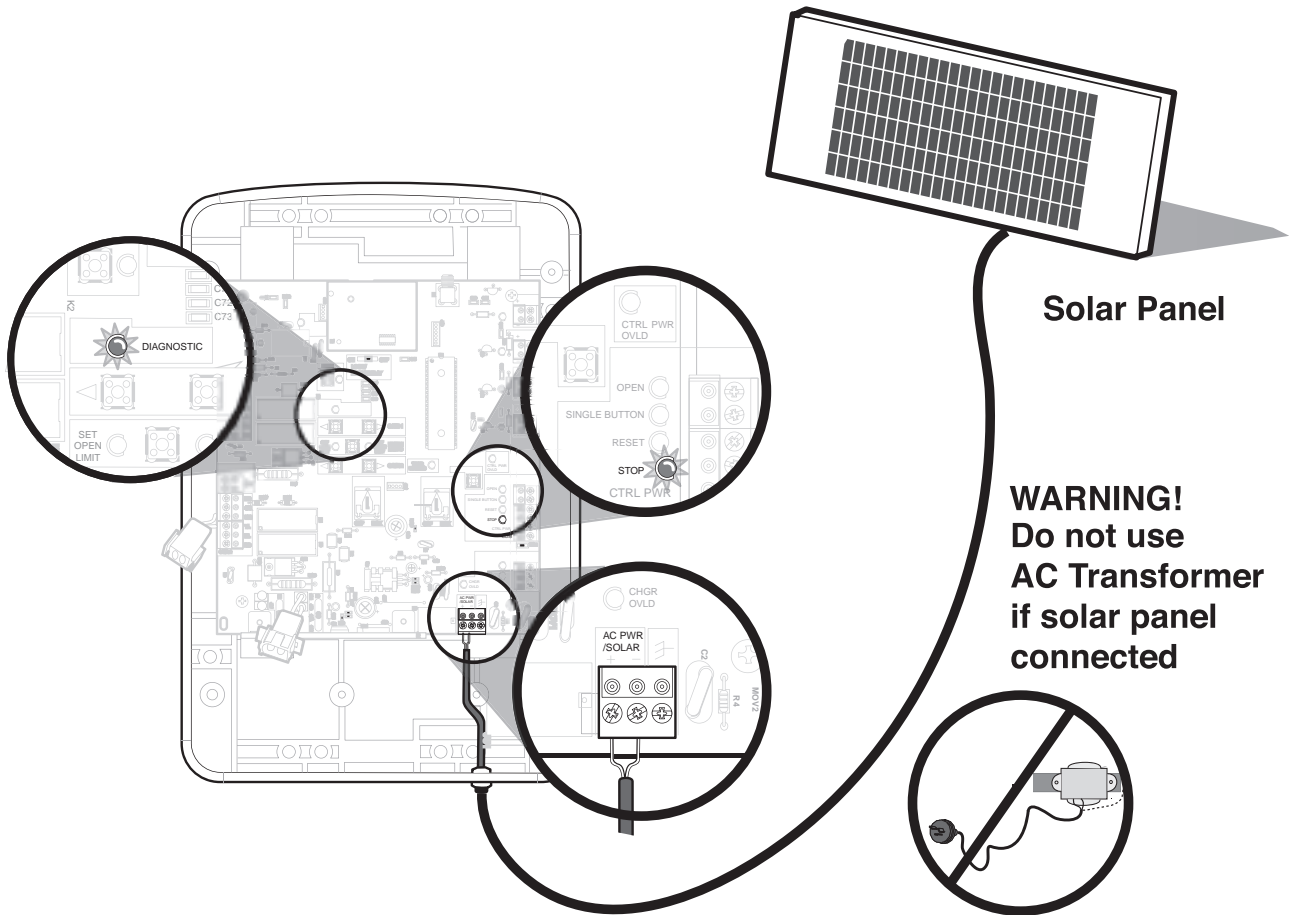

CONNECTING POWER TO THE CONTROL BOARD UNIT

For outdoor connection, a properly earthed WEATHER PROOF POWER POINT MUST BE USED.

NOTE: Connection of Power must comply to local electrical standards.

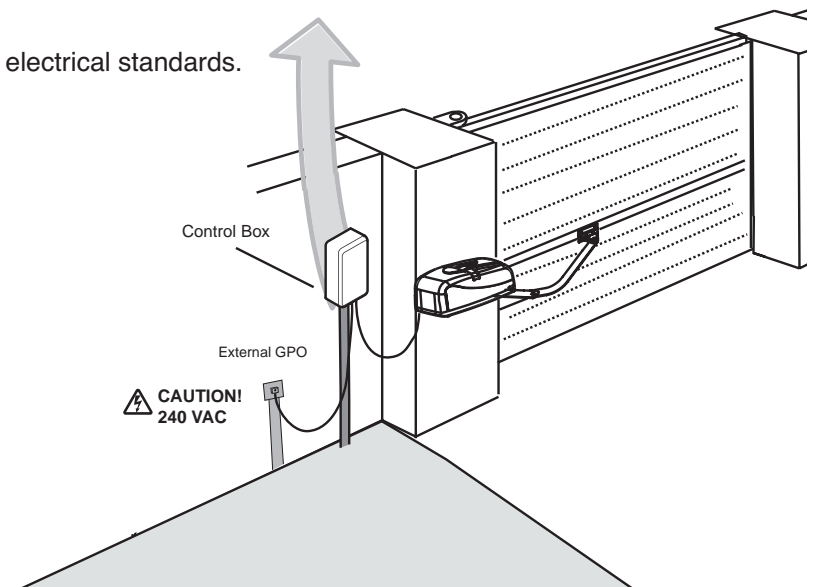

CONNECT BATTERIES

The batteries are charged in circuit by using the transformer (provided).
Locate the two white battery plugs on the left-hand side of the control box.
Connect the plug from the battery to connector on the control board. Either connector can be used for a single battery.

NOTES: Batteries will degrade over time depending on temperature and usage. For best performance, the batteries should be changed every 3 years. Batteries do not perform well in extremely cold temperatures. For locations where the temperatures are below -20° C (-4°F) contact technical support.

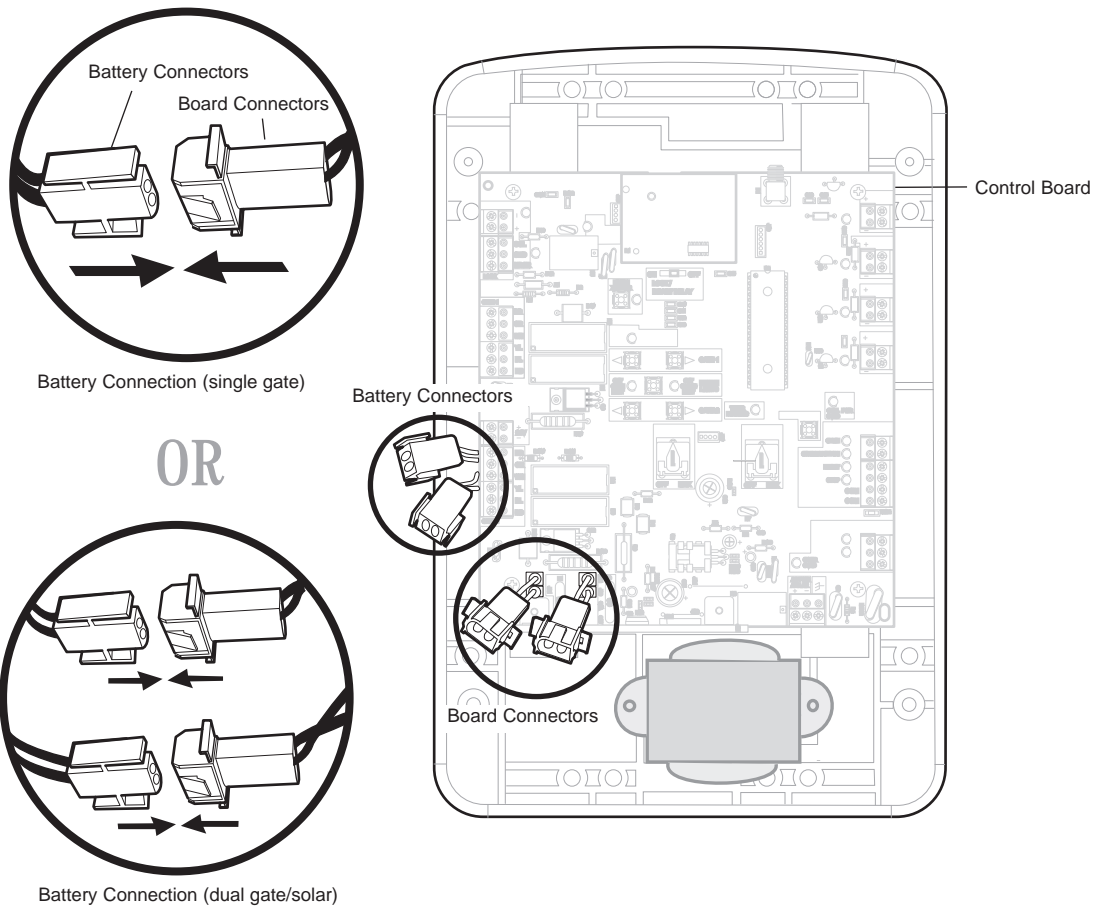

SETTING THE CAMS FOR MGA600

The CAM switches must be set before proceeding with any programming. Either CAM can be used for “open” or “closed” position.

To set the CAM switches, disengage the motor using the Hex key provided.

Remove the top cover of the motor to allow access to the CAM located at the top of the motor (keys to access the cover are provided with the gate operator).

Manually move the gate through one complete action. The micro switches make a clicking sound as the CAM begins to engage them.

Open Limit:

Set the CAM so the open limit microswitches click about 10 degrees before the desired open position.

Closed Limit:

The closed limit microswitch should click about 10 degrees before the gate is at the desired closed position.

NOTE: The cams are set for use as passpoints (references) NOT THE OPEN AND CLOSED POSITIONS. A useful rule of thumb is to set the click to the point at which the soft stop & soft stop engage. Limit programming detailed on pages 19 and 20.

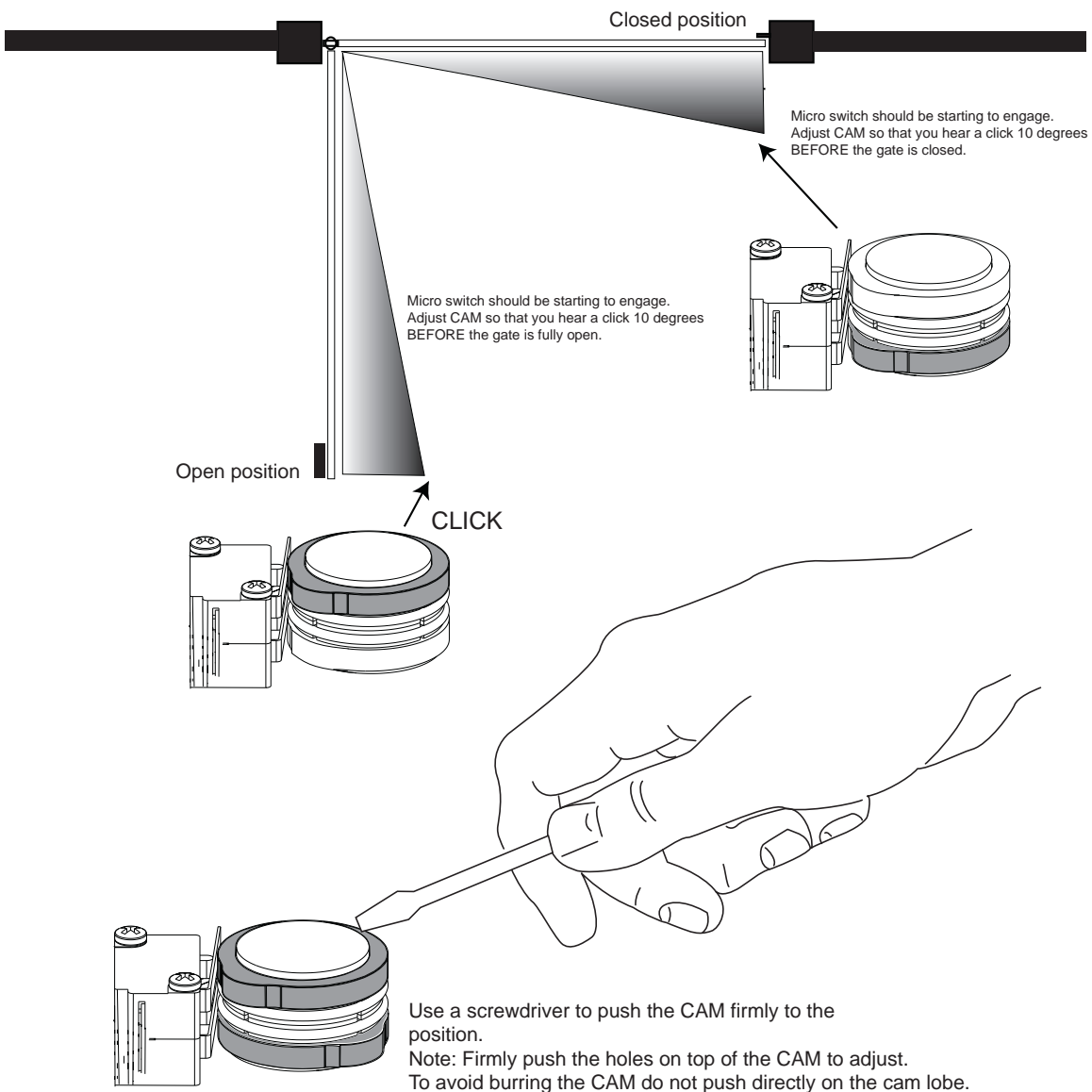
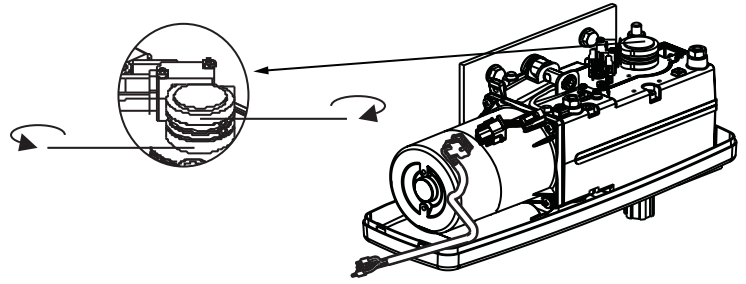

PROGRAMMING

Program Limits

The limits are internal settings that indicate when the gates are in the fully open position and the fully closed position. For proper functionality, the limits must be learned during the installation process. The programmed limit process uses a combination of buttons on the control board.

The specific buttons used for programming depends on which side of the gates the control box is mounted on and how many operators the installation includes.

If a mistake is made during the programming process press the **RESET** button on the outside of the control box to start over.

SINGLE ARM LEFT-HAND SIDE

SINGLE ARM RIGHT-HAND SIDE

NOTE: The "Learn Limits" mode can be exited at any time by pressing the **RESET** button. The mode will time-out automatically after 60 seconds of inactivity.

PROGRAM OPEN

With the gate in the **closed** position, press the **LEARN LIMITS** button (**SET OPEN LIMIT** LED will blink).

LEARN LIMITS button

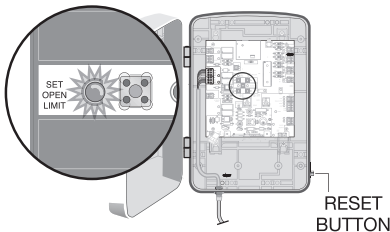

Press the **GATE 1** right button to move gate to the desired OPEN position. When gate is in the desired position, press the **LEARN LIMITS** button again. Control board will beep.

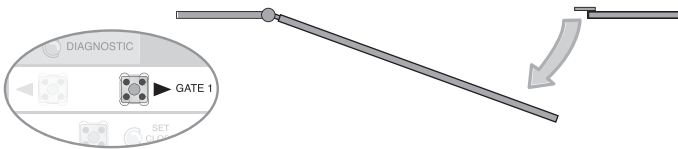

PROGRAM CLOSE

Press the **GATE 1** left button to move gate to the desired CLOSED position. When gate is in the desired closed position, press the **LEARN LIMITS** button again.

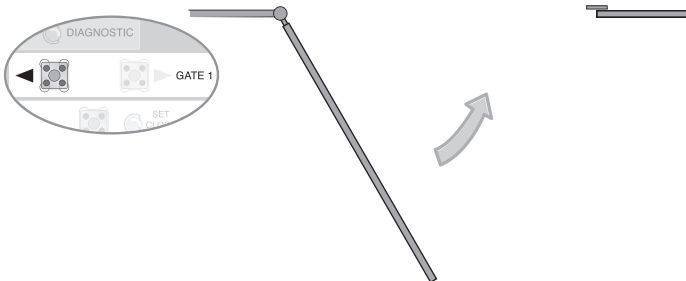

PROGRAM OPEN

With the gate in the **closed** position, press the **LEARN LIMITS** button (**SET OPEN LIMIT** LED will blink).

LEARN LIMITS button

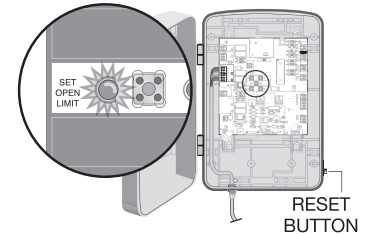

Press the **GATE 1** left button to move gate to the desired OPEN position. When gate is in the desired position, press the **LEARN LIMITS** button again. Control board will beep.

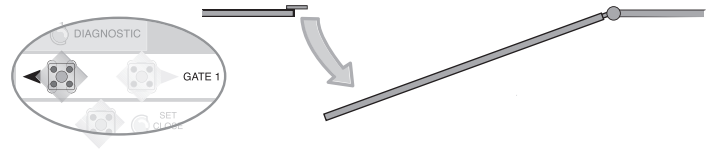

PROGRAM CLOSE

When the **SET CLOSE LIMIT** LED blinks, press the **GATE 1** right button. When gate is in the desired closed position, press the **LEARN LIMITS** button.

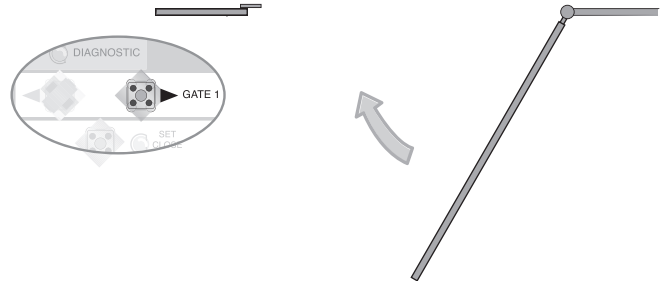

When control board beeps and the **SET OPEN LIMIT** and **SET CLOSE LIMIT** LEDs stop blinking, programming is now complete.

Test the limits by pressing the SBC to open and close the gate.

NOTE: If the **SET OPEN LIMIT** LED is still blinking, the limits were not programmed successfully. Repeat the programming making sure the gate is fully opened and closed for each respective limit. If the problem persists, refer to the Troubleshooting section.

NOTES:

- If one gate is overlapping the other, the gate that is overlapping must be connected to GATE 1 so it will start moving before the other gate; gate 2 may need to be closed first if there is overlap or a gate lock is being used.
- The programming can be exited at any time by pressing the RESET button. Programming times-out automatically after 60 seconds of inactivity.

DUAL GATE (LEFT-SIDE PRIMARY OPERATOR)

PROGRAM OPEN

With the gate in the **CLOSED** position, press the **LEARN LIMITS** button (**SET OPEN LIMIT** LED will blink).

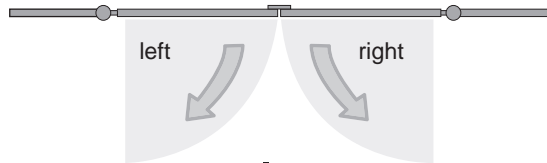
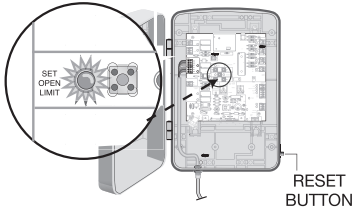

Press the **GATE 1** right button to open the left side operator.

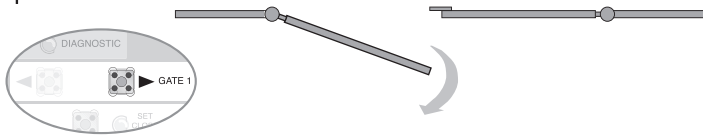

Press the **GATE 2** right button to move the right side operator into the OPEN position.

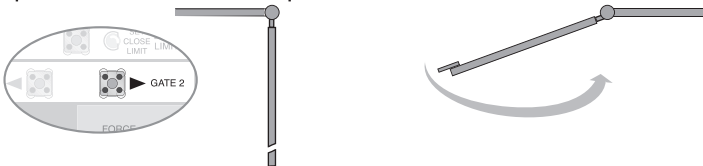

Press the **LEARN LIMITS** button. Control board will beep.

PROGRAM CLOSE

When the **SET CLOSE LIMITS** LED blinks, press the **GATE 2** left button to close the right operator.

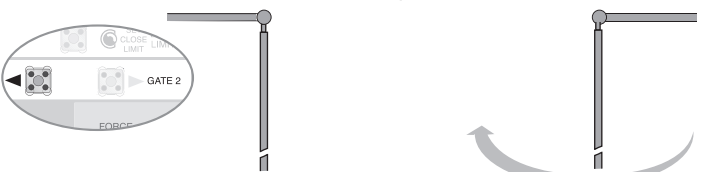

Press the **GATE 1** left button to close the left operator.

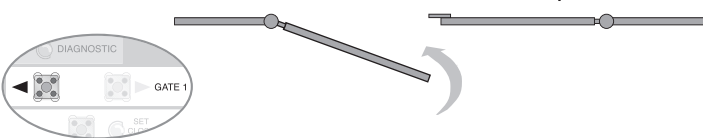

Press the **LEARN LIMITS** button.

DUAL GATE (RIGHT-SIDE PRIMARY OPERATOR)

PROGRAM OPEN

With the gate in the **CLOSED** position, press the **LEARN LIMITS** button (**SET OPEN LIMIT** LED will blink).

Press the **GATE 1** left button to open the right side operator.

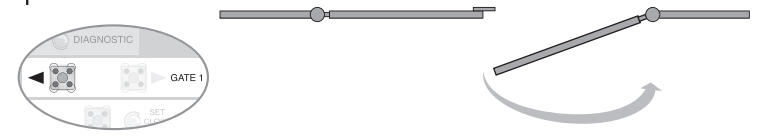

Press the **GATE 2** left button to move the left side operator into the OPEN position.

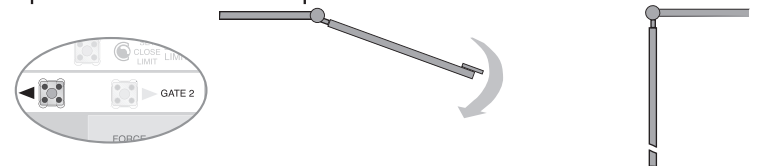

Press the **LEARN LIMITS** button. Control board will beep.

PROGRAM CLOSE

When the **SET CLOSE LIMITS** LED blinks, press the **GATE 2** right button to close the left operator.

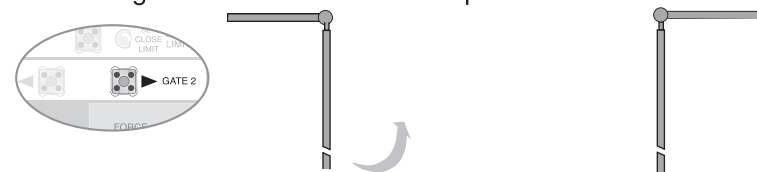

Press the **GATE 1** right button to close the right operator.

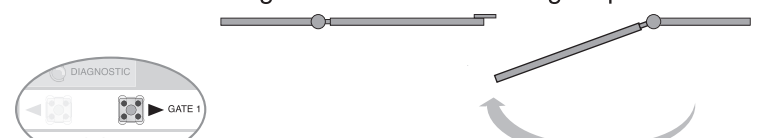

Press the **LEARN LIMITS** button.

When control board beeps and the **SET OPEN LIMIT** and **SET CLOSE LIMIT** LEDs stop blinking, programming is now complete.

Test the limits by pressing the SBC to open and close the gate.

NOTE: If the SET OPEN LIMIT LED is still blinking, the limits were not programmed successfully. Repeat the programming making sure the gate is fully opened and closed for each respective limit. If the problem persists, refer to the Troubleshooting section.

Force/Timer to Close/Party Mode Controls

FORCE ADJUSTMENT

The operator is equipped with an obstruction sensing feature. If the gate encounters an obstruction the operator will automatically reverse direction and stop. Based on the length and weight of the gate it may be necessary to make force adjustments. The force adjustment should be high enough that small objects such as branches or wind will not cause nuisance interruptions but low enough to prevent serious injury to a person or a vehicle.

To adjust the force:

Using the remote control transmitter or the Single Button Control (SBC) button on the control board, open and close the gate.

If the gate stops and or reverses before reaching the fully open or closed position increase the force by turning the force control slightly. Run operator through a complete cycle.

NOTE: Weather conditions can affect the gate movement, so seasonal adjustment may be required. The force control is factory set to the mid position.

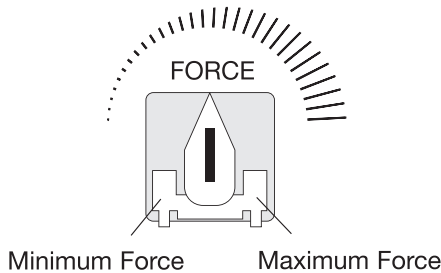

TIMER-TO-CLOSE (TTC)

NOTE: Safety IR Beams must be installed if this feature is being used.

The **TIMER TO CLOSE** feature can be set to automatically close the gate after a specified time period.

If the TTC is set to the OFF position, then the gate will remain open until the operator receives another command from a remote control or SBC.

To set the TIMER TO CLOSE:

Rotate the **TIMER TO CLOSE** dial to the desired setting. The range is 0 to 180 seconds, 0 seconds is OFF.

NOTE: Any radio command, SBC, or CLOSE command on the control board prior to the TTC expiring will close the gate. The TTC is reset by any signals from the loops, close edges, and close safety sensors (IR's).

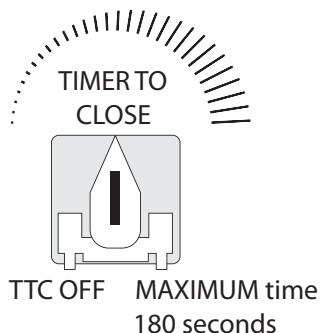

⚠ WARNING

Without a properly installed safety reversal system, persons (particularly small children) could be **SERIOUSLY INJURED** or **KILLED** by a closing gate.

- Too much force on gate will interfere with proper operation of safety reversal system.
- NEVER increase force beyond minimum amount required to close gate.
- NEVER use force adjustments to compensate for a binding or sticking gate.
- If one control (force or travel limits) is adjusted, the other control may also need adjustment.
- After ANY adjustments are made, the safety reversal system **MUST** be retested. Gate **MUST** reverse on contact with a rigid object.

PARTY MODE

TTC can be temporarily disabled by pressing RESET button (located on the outside side of the control box) when the gate is fully open. This will allow the gate to remain open until another command is received. After the next command to the operator, TTC returns to the previously set time period.

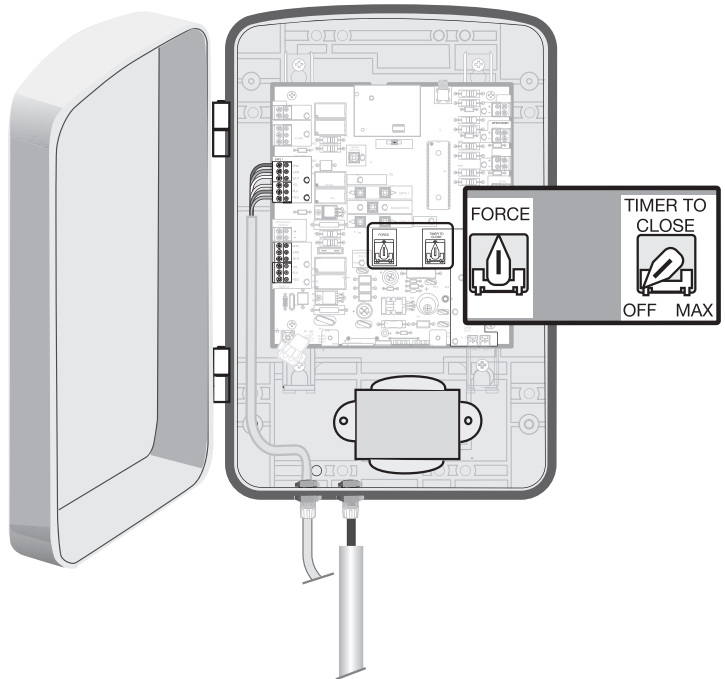

To Add or Reprogram a Remote Control (not provided)

1. Press **LEARN XMITTER** button and release (LED will light up).
2. Press remote button, the LED will flash, alarm output will activate twice.
3. Repeat steps 1 and 2 until all remote controls are programmed (9 remote controls maximum).

NOTE: For highest level of security, we recommend the Security **+** line of products. Refer to Accessories.

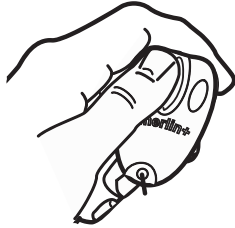

WARNING

To prevent possible **SERIOUS INJURY** or **DEATH** from a moving gate or garage door:

- **ALWAYS** keep remote controls out of reach of children. **NEVER** permit children to operate, or play with remote control transmitters.
- Activate gate **ONLY** when it can be seen clearly, is properly adjusted, and there are no obstructions to gate travel.
- **ALWAYS** keep gate in sight until completely closed. **NEVER** permit anyone to cross path of moving gate.

To Add a Wireless Keyless Entry C840 (not provided)

1. Press **LEARN XMITTER** button and release (LED will light up).
2. Enter a four digit personal identification number (PIN) of your choice on the keypad.
3. Then press **ENTER**, the LED will flash, alarm output will activate twice.

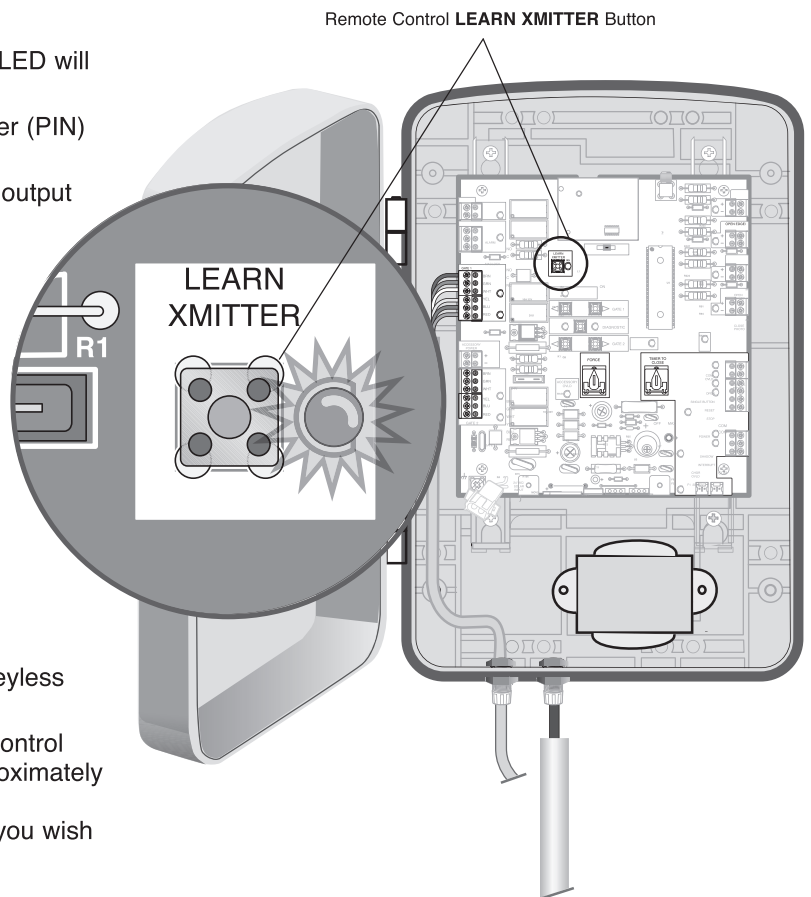
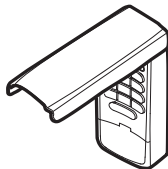

TO ERASE ALL CODES

To deactivate any unwanted remote controls or keyless entries, all codes must be erased.

Press and hold the **LEARN XMITTER** button on control board until the learn indicator light goes out (approximately 6 seconds). All previous codes are now erased.

Reprogram each remote control or keyless entry you wish to use.

Make sure the rubber seal around the cover is intact and close the cover. Secure the control box cover with screws (4). Installation is complete.

NOTE: Failure to seal the control box may allow moisture to enter, and may cause the opener to be inoperable. If you are unsure call your local installer, a call out fee will apply.

OPERATION OF YOUR GATE OPENER

Using Your Gate Operator

Your operator will operate with up to nine Security+® remote controls and one Security+® Keyless Entry System. If you purchase a new remote, or if you wish to deactivate any remote, follow the instructions in the Programming section.

Activate your operator with any of the following:

Hand Held Remote Control (See Accessories): Hold push button down until the gate begins to move. While gate is moving, the next command sent from the remote will stop the gate. Next command will reverse the gate direction.

Keyless Entry (See Accessories): If provided with your gate operator, it must be programmed before use. See Programming.

Vehicle Exit Sensor: See accessory page.

ENTRAPMENT FEATURES

When the operator is activated (with the safety sensors correctly installed and aligned) and the safety sensors encounter an obstruction, the following will occur:

Opening Cycle: Gate will stop, reverse direction for approximately 2 seconds and then stop. The next command will continue the gate in the close direction.

Closing Cycle: Gate will stop, reverse direction for approximately 2 seconds and then stop. The next command will open the gate.

ALARM SOUNDS

The operator alarm will sound under the following condition: If gate encounters two consecutive obstructions, the operator will stop, the alarm will sound (up to 5 minutes) and the control board will require resetting. Reset the control board by pressing the "Reset Button" located on the outside of the control box. No commands at this time will operate gate. After the operator is reset, normal functions will be available.

MANUAL RELEASE

The release lock for the casing is located under the rubber weatherproof cover. Use the socket spanner supplied in the hardware bag to lift the cover up. The release key located beneath the hood should be inserted into the side openings and turned approx. 180 degrees until it cannot turn any further. The drive has now been released. To re-engage it, the key should be turned back to its original position.

NOTE: Take care when unlatching the drive for manual operation. The gate panel can move in an unconditional way, especially if it is mounted on a sloped position.

AUTOMATIC TIMER TO CLOSE FEATURE

The Timer-To-Close (TTC) Feature comes from the factory in the OFF setting.

TIMER TO
CLOSE

The "TIMER RUNNING LED" will flash once for every second of adjusted time. The gate(s) must fully open for the timer feature to be active and close the gate(s). Any radio command or pressing the single button on the control board prior to the TTC time expiring will close the gate. The TTC is reset by any signals from the loops, close edges, and close safety sensors (IR's).

OFF MAX

PARTY MODE

If the Timer-to-Close feature is enabled and you would like the gate to remain open, simply push the reset button (located on the outside of the control box). The next command given to the operator will close the gate and return the operator to normal operation.

SLEEP MODE (BATTERY CONSERVATION)

Sleep Mode (Battery Conservation): The operator enters sleep mode 10 seconds after the last command is given. The diagnostic LED will blink in this mode. The safety sensors (photo eyes) indicator LEDs will not be on. The next operation command will return the operator to normal operation.

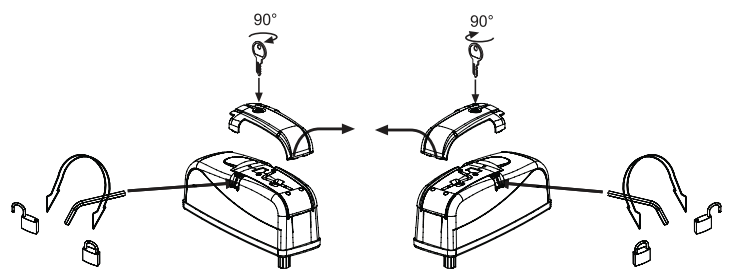
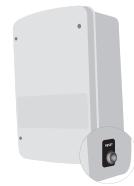

Wiring Diagram

⚠ WARNING

To protect against fire and electrocution:

- DISCONNECT power and battery BEFORE installing or servicing operator.
- For continued protection against fire:
- Replace ONLY with fuse of same type and rating.

1. Antenna Input
 2. Close Edge*
 3. Open Edge/Photo*
 4. Open Photo*
 5. Close Photo*
 6. Control Inputs*
 7. Loop Inputs*
 8. AC PWR/SOLAR
 9. Gate 2
 10. Accessory Power*
 11. Gate 1
 12. Lock (Solenoid/Maglock) Output*
 13. Alarm Output*
 14. Battery 1 Connector
 15. Battery 2 Connector
 16. Lock/BiPart Delay
 17. Learn Xmitter
 18. Primary Gate Jog
 19. Learn Limits
 20. Secondary Gate Jog
 21. Force
 22. Timer To Close (TTC)
 23. Receiver Module 433.92 Mhz
 24. Fuses (20 Amp)
- *Class 2 circuit 15 V maximum output

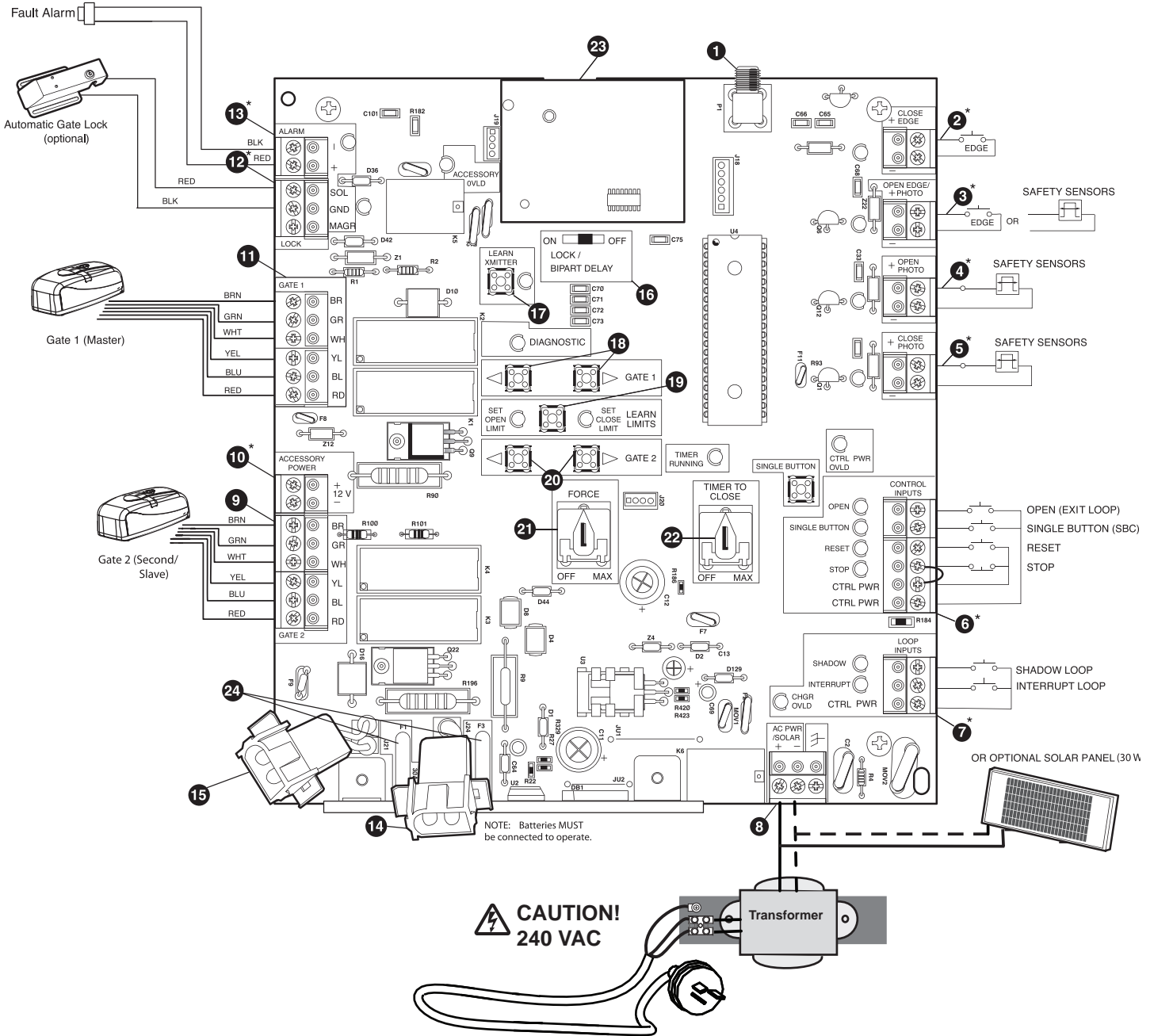

CONTROL INPUTS

Refer to Wiring Diagram on page 24.

WIRE STOP BUTTON (OPTIONAL)

A jumper wire is factory installed between the stop and common input.

Stop (N/C) - Stop only (does not reset alarm).

NOTE: Stop jumper is required for normal operation (the Stop LED will be lit except when the control board goes into Sleep Mode). Remove only if remotely mounted Stop button is added.

OPEN

Opens only or reverses a closing gate.

SBC (SINGLE BUTTON CONTROL) INPUT

This input will command the gate to OPEN / STOP / CLOSE / STOP in sequence.

RESET CONTROL INPUT

The control box has a factory installed internal reset button. These terminals are intended for use with a single reset button that is installed within a line of sight of the gate. This input functions to reset the alarms. This input will NOT stop the gate.

NOTE: All control inputs must be Normally Open (N.O.) dry contact type.

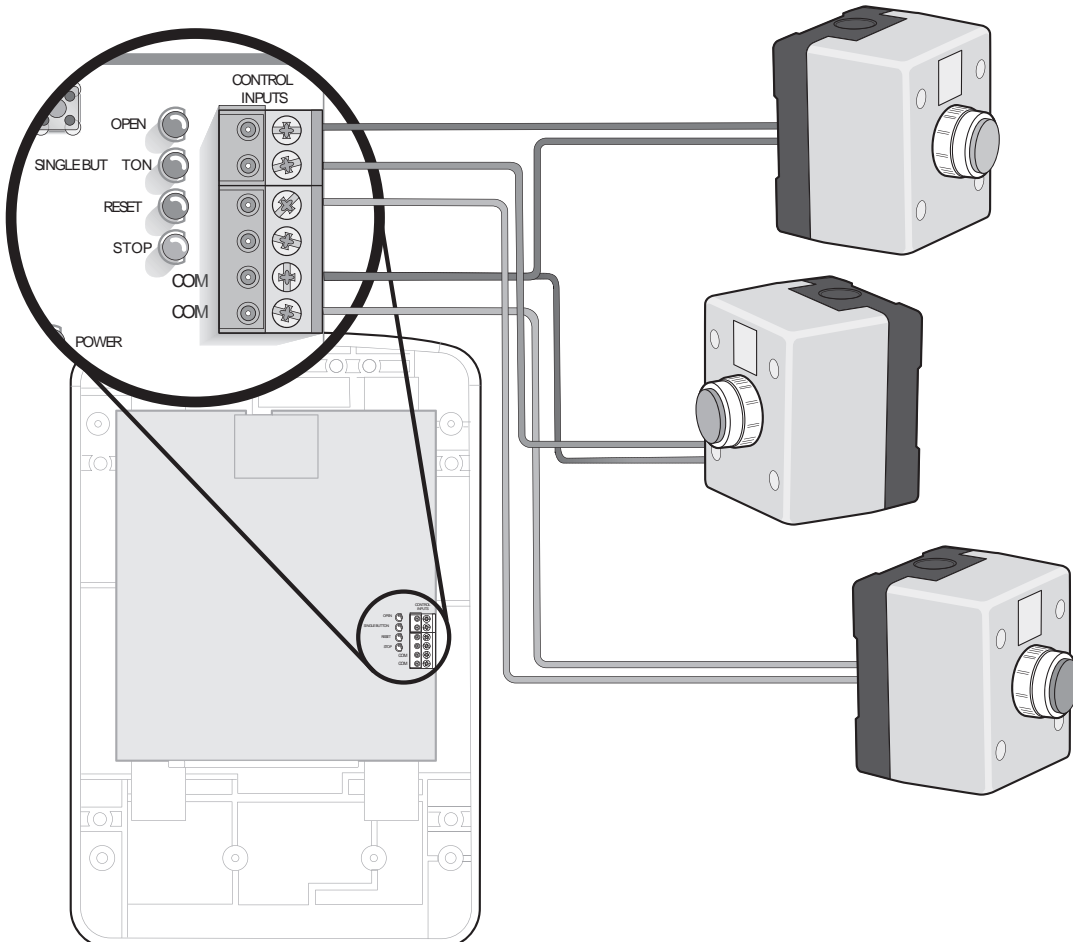
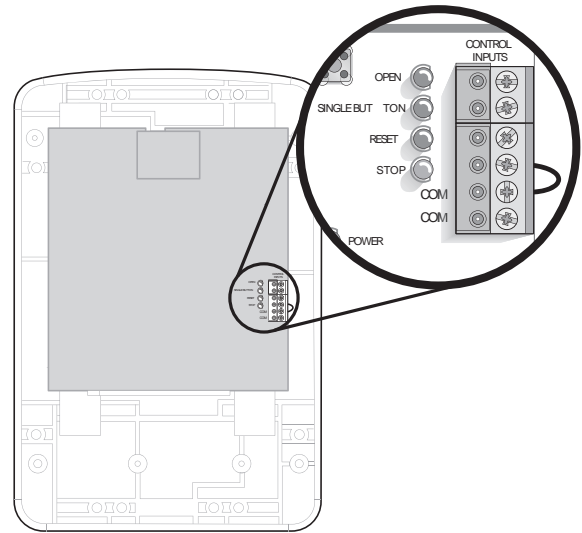

Diagnostic Chart

Your gate operator is programmed with self-diagnostic capabilities. The diagnostic LED will flash a number of times then pause signifying it has found a potential issue. Consult Diagnostic Chart below.

1 FLASH	● Normal Operation
Power ON 2 FLASHES STOP not connected	● Stop is not connected. ● Press the RESET button and make sure the STOP LED turns on. ● Check to make sure the jumper wire is connected between the COM and STOP input on the control board. Stop is a normally closed input.
3 FLASHES Low Battery Voltage	● Battery voltage is below the recommended operating level. ● Battery may not be properly charged. Disconnect all batteries and make sure AC power or solar power is connected. Verify AC power outlet. ● Verify that the battery fuses are intact and not blown. Replace blown fuses with same type and rating. ● Batteries are no longer capable of holding a charge due to age or excessive depleting of the battery. Replace the batteries (see accessories page). Dispose of old batteries properly.
4 FLASHES Low Battery Capacity	● Battery voltage is below the recommended operating level. ● Battery may not be properly charged. Disconnect all batteries and make sure AC power or solar power is connected. Verify AC power outlet. ● Verify that the battery fuses are intact and not blown. Replace blown fuses with same type and rating. ● Batteries are no longer capable of holding a charge due to age or excessive depleting of the battery. Replace the batteries (see accessories page). Dispose of old batteries properly.
5 FLASHES RPM Reversal Gate 1 or Arm Disconnected	● Gate 1 has encountered an obstruction or the arm is disconnected. ● Make sure the path of the gate is clear and the gate moves freely. ● Incorrect or poor connection to Gate 1 arm. Check the green and white wires on the motor arm to make sure connections are correct and secure. ● Bad arm or control board. Press the LEARN LIMITS button and press the GATE 1 buttons to move the arm. If the arm does not move continuously, disconnect arm from Gate 1 and connect the arm to the Gate 2 connector and repeat the attempt to move the arm. If the arm does not move continuously on either Gate 1 or 2, replace the arm.
6 FLASHES Force Reversal Gate 1	● Gate 1 has encountered an obstruction. ● Make sure the path of the gate is clear and the gate moves freely. ● If there is no obstruction the force adjustment is set too low. Increase the force setting and verify that the gate moves without reversing and will reverse if an obstruction is encountered.
7 FLASHES RPM Reversal Gate 2 or Arm Disconnected	● Gate 2 has encountered an obstruction or the arm is disconnected. ● Make sure the path of the gate is clear and the gate moves freely. ● Incorrect or poor connection to Gate 2 arm. Check the green and white wires on the motor arm to make sure connections are correct and secure. ● Bad arm or control board. Press the LEARN LIMITS button and press the GATE 2 buttons to move the arm. If the arm does not move continuously, disconnect arm from Gate 2 and connect the arm to the Gate 1 connector and repeat the attempt to move the arm. If the arm does not move continuously on either Gate 1 or 2, replace the arm.
8 FLASHES Force Reversal Gate 2	● Gate 2 has encountered an obstruction. ● Make sure the path of the gate is clear and the gate moves freely. ● If there is no obstruction the force adjustment is set too low. Increase the force setting and verify that the gate moves without reversing and will reverse if an obstruction is encountered.
9-11 FLASHES Potential chip failure	● Potential RAM, Flash, or EPROM failure. ● Turn power off and on. ● If problem does not resolve itself by turning power off and on, replace the control board.

Troubleshooting

SYMPTOM	POSSIBLE SOLUTION
Operator does not run. Diagnostic LED not on.	<ul style="list-style-type: none"> • Power not connected. Make sure the AC/Solar input is connected and that at least one battery is connected with the corresponding fuse intact. • Low or defective battery. Check the battery to make sure that the red wire goes to the positive terminal of the battery and the black wire goes to the negative terminal of the battery. Replace the battery if the open circuit voltage is below 11.5Vdc. • Bad control board. Call technical support for more options.
Operator powers up but does not run.	<ul style="list-style-type: none"> • Low or defective battery. At least one charged battery must be connected for the unit to operate. Verify the battery fuse is intact. Check battery connections and battery voltage to be above 11.5V. Replace batteries if necessary. • STOP button connection loose or disconnected. Press the RESET button and verify that the STOP LED lights up and then turns off after 10 seconds. Verify the wire connects between the STOP and CTRL PWR terminals. • Obstruction blocking safety sensors. Press the RESET button and verify that all the safety LEDs (OPEN EDGE/PHOTO, OPEN PHOTO, CLOSE PHOTO) are OFF. If any are ON, clear any obstructions and verify the LED turns off. NOTE: The RESET button may need to be hit multiple times since the LEDs turn off after 10 seconds when the unit goes to sleep. • (Optional Accessory) Safety edge is damaged or on an obstruction. Press the RESET button and verify that the Safety LEDs (OPEN EDGE and CLOSE EDGE/PHOTO) are OFF. If either is ON, clear any obstructions and verify the LED turns off. NOTE: The RESET button may need to be hit multiple times since the LEDs turn off after 10 seconds when the unit goes to sleep. • (Optional Accessory) Interrupt loop or Shadow loop is obstructed. Press the RESET button and verify that the INTERRUPT and SHADOW LEDs are OFF. If either is on, check the loop detector and its wiring to insure that it is not incorrectly being triggered.
Relays “click” when remote control or single button control (SBC) command is given, but the operator does not move.	<ul style="list-style-type: none"> • Bad control board. Call technical support for help with replacement parts. • Battery not connected. At least one charged battery must be connected for the unit to operate. Verify battery fuse is intact. Check battery connections and battery voltage to be above 11.5V. Replace batteries if necessary. • Arm cable loose or disconnected. Verify that all of the wires, especially the red and blue wires, going to the arm are secure and that the connector is properly mated to the header. • Arm is jammed or incorrectly installed. Disconnect the motor housing from the arm and verify that the arm moves freely. With the motor housing still disconnected, enter the Learn Limits mode and verify that the motor spins. Reconnect the motor housing to the arm and make sure that all 4 screws are securely tightened and that the motor seats correctly against the worm drive. Relearn limits for the operator. • Bad control board. Call technical support for help with replacement parts.

SYMPTOM	POSSIBLE SOLUTION
The arm moves but cannot exit Learn Limits mode. Cannot learn limits.	<ul style="list-style-type: none"> • Arm does not extend or contract enough during travel. The arm piston must extend and contract close to its full length to Learn Limits. Adjust the arm mounting so that this can be achieved. • Motor cable wire not connected. Make sure that all the motor wires are connected properly. • Motor housing is not properly seated. Make sure that the motor housing for the arm(s) is properly seated so there are no gaps between the motor housing and arm assembly. Make sure all 4 screws are tightened.
Gate does not fully open or close when trying to learn limits.	<ul style="list-style-type: none"> • Over extending or contracting arm. Disconnect the motor housing from the arm and make sure that the arm moves freely throughout the full length of travel. Adjust arm mounting and positioning if necessary. • Arm is interfering with the gate mount bracket. Examine the hinge point where the arm mounts to the gate post. Make sure that the arm housing does not hit or interfere with the gate post or mounting bracket throughout the full length of travel. Adjust the arm mounting and positioning if necessary. • Gate is excessively heavy or hinges are bad. Verify that the gate is within the ratings for this product. Disconnect the arms and verify that both gates swing easily. Lubricate or replace hinges as necessary.
Unit does not respond to single button control (SBC) command.	<ul style="list-style-type: none"> • Battery not connected. At least one charged battery must be connected for the unit to operate. Verify the battery fuse is intact. Check battery connections and battery voltage to be above 11.5Vdc. Replace batteries if necessary. • STOP button connection loose or disconnected. Press the RESET button and verify that the STOP LED lights up and then turns off after 10 seconds. Verify the wire connects between STOP and CTRL PWR terminals. • Single Button Control (SBC) button connection loose. Check wiring for SBC button. Use the on-board single button to verify operator will respond. • Bad control board. Call technical support for help with replacement parts.
Unit does not respond to remote control command.	<ul style="list-style-type: none"> • Battery not connected. At least one charged battery must be connected for the unit to operate. Verify battery fuse is intact. Check battery connections and battery voltage to be above 11.5V. Replace batteries if necessary. • STOP button connection loose or disconnected. Press the RESET button and verify that the STOP LED lights up and then turns off after 10 seconds. Verify the wire connects between the STOP and CTRL PWR terminals. • Radio module not plugged in. Verify the green Radio module (located next to the coaxial connector) is properly mated with both 4-pin connectors. • Antenna not connected. Verify the antenna and coaxial cable are properly connected to the control board. • Transmitter not learned. Refer to Programming Remote Control section for steps to program the transmitter. • Bad control board. Call technical support for help with replacement parts.
Gate stops and reverses immediately after it starts moving.	<ul style="list-style-type: none"> • Obstruction sensed. Check safety devices and gate for obstructions. • A fault has occurred. Check Diagnostic LED for possible error codes. • Force set too low. Adjust FORCE setting until gate completes a full open/close cycle without reversing. The force setting may need to be adjusted in cold weather, as the gate will not move freely. • Loops are reversed. Make sure that the Safety loop and Shadow loop are connected properly. The gate may trigger the Shadow loop as it moves, so it must be connected to the correct input. • Low or defective battery. At least one charged battery must be connected for the units to operate. Verify battery fuse is intact. Check battery connections and battery voltage to be above 11.5V. Replace batteries if necessary.

SYMPTOM	POSSIBLE SOLUTION
Gate opens but does not close.	<ul style="list-style-type: none"> • An open input is continuously activated. Check the open loop or vehicle probe to make sure they are clear of objects. Verify connections and operation for these devices. • Low battery. Measure the voltage across the battery. Voltage should be above 11.5Vdc. Replace battery if required. • (Optional Accessory) Entry system output is connected to the OPEN input, and is “stuck” opening. Verify entry system connections and operations. • Obstruction blocking close photo eyes, shadow loop, or safety loop. Check eyes for alignment and verify all connections and operation for safety devices. • (Optional Accessory) Close safety edge is damaged or on an obstruction. Verify operation and connection of close edge.
Gate does not close automatically with Timer to Close enabled.	<ul style="list-style-type: none"> • Verify that the Timer to Close is ON and adjusted to desired delay. • Gate opened by a force obstruction reversal. Check the Diagnostic LED and clear gate path of any obstructions. • The Interrupt loop or Shadow loop is obstructed (optional accessories). • Obstructed close safety sensor or safety edge (optional accessory). Check connections and operations of safety devices. • Low battery. Measure the voltage across the battery. Voltage should be above 11.5Vdc. Replace battery if required. • An open input is continuously activated. Check the open loop or vehicle probe to make sure they are clear of objects. Verify connections and operation for these devices. • (Optional Accessory) Entry system output is connected to the OPEN input, and is “stuck” opening. Verify entry system connections and operation. • Operator in “Party” mode after RESET button pressed while at the OPEN limit. Use a remote or the SBC to close the gate and reopen it. Verify that the TIMER RUNNING LED is flashing.
Alarm constantly sounds for 5 minutes. Sounds whenever a command is issued.	<ul style="list-style-type: none"> • Double entrapment occurred. Two successive obstructions were encountered while moving the gate. Press the RESET button and ensure that the gate path is clear of all obstructions. Check the FORCE setting to make sure it is properly set.
Alarm is beeping 3 times on a command.	<ul style="list-style-type: none"> • Low battery. Measure the voltage across the battery. Voltage should be above 11.5Vdc. Replace battery if required.
Gate runs too slow.	<ul style="list-style-type: none"> • Open and Close Limits are set too close together. If the Open and Close Limits are set within the ramp down distance of each other, the gate will run at slow speed all the time. • The gate is starting within the ramp down distance from the Open or Close Limit. Gate will run slow to limits if motion is started within the ramp-down distance from the limit.
Gate 2 closes before Gate 1.	<ul style="list-style-type: none"> • Lock/Bipart Delay not set. Slide the Lock/Bipart Delay switch to ON. Verify that Gate 1 starts moving first on open and last on close. • Gate is excessively heavy or hinges are bad. Verify that the gate is within the ratings for this product. Disconnect the arms and verify that both gates swing easily. Lubricate or replace hinges as necessary. • Gate is unbalanced. Disconnect the arms and verify that both gates swing easily in both directions. If the gates are harder to move in one direction verses the other, the gate is not properly balanced and the hinges must be adjusted. • Bad motor connection. Check the motor wires and connections for possible loose or corroded terminals.
Alarm beeps when running.	<ul style="list-style-type: none"> • Low battery. Measure the voltage across the battery. Voltage should be above 11.5Vdc. Replace battery if required.
Gate does not open/close at the same place each time.	<ul style="list-style-type: none"> • In windy areas, an automatic gate lock for close and a hard stop for open is recommended to ensure the gate stops in the same place each time. • Periodic limit adjustments may be necessary.

SPARES

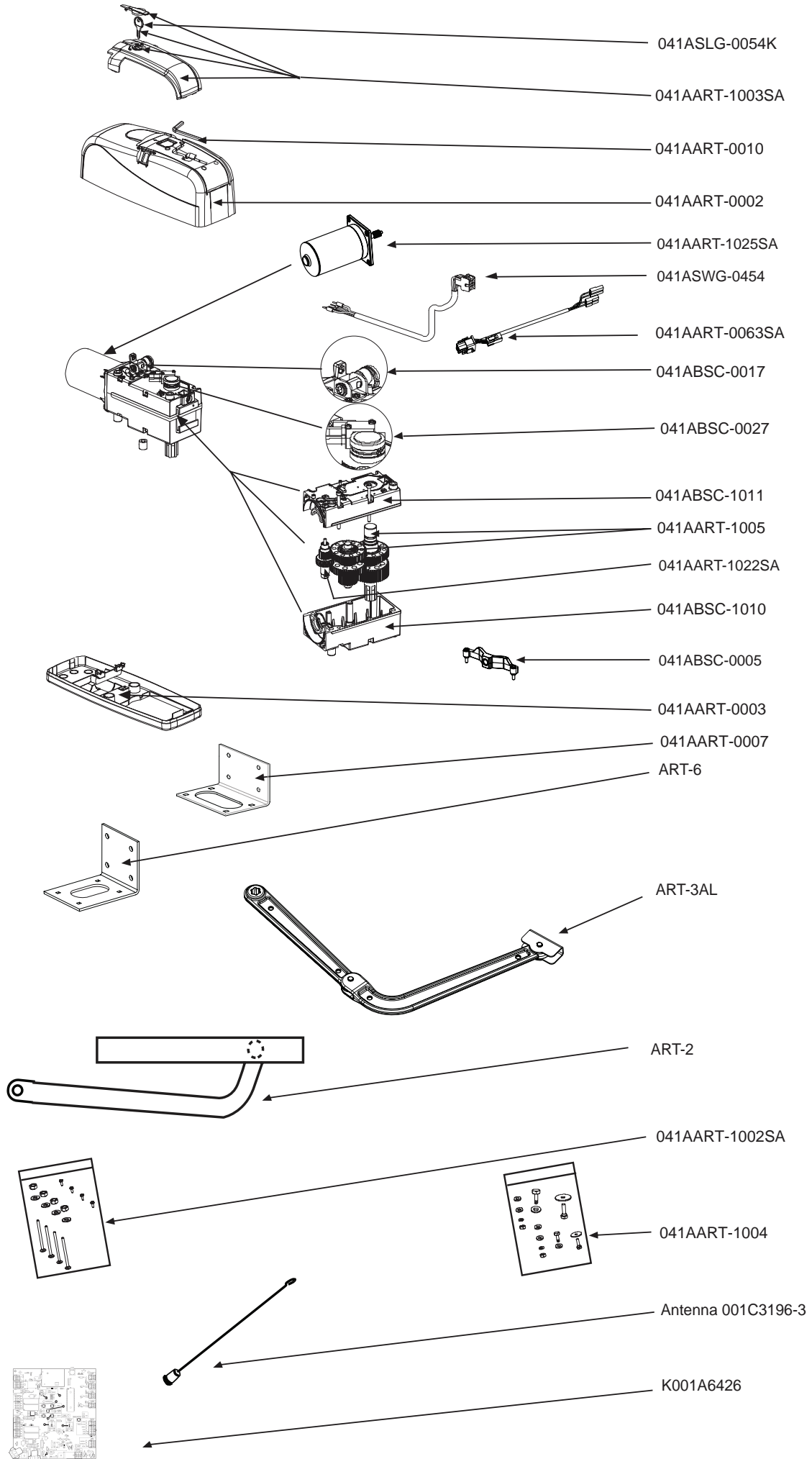

CHAMBERLAIN LIMITED WARRANTY
Merlin Professional MGA600
Articulated Swing Gate Opener

Chamberlain Australia Pty Limited / Chamberlain New Zealand Limited (Chamberlain), the manufacturer of Merlin® automatic gate openers, is committed to manufacturing and supplying high quality goods.

As part of this commitment, we seek to provide reliable service and support for our goods and are pleased to provide you, the original purchaser, with this Chamberlain Limited Warranty.

We also provide the following statement as required by the Australian Consumer Law: In Australia, in addition to your rights under this Chamberlain Limited Warranty, our goods come with guarantees that cannot be excluded under the Australian Consumer Law. You are entitled to a replacement or refund for a major failure and for compensation for any other reasonably foreseeable loss or damage. You are also entitled to have the goods repaired or replaced if the goods fail to be of acceptable quality and the failure does not amount to a major failure.

Chamberlain's warranty

Chamberlain warrants to the original purchaser of the Merlin® Swing Gate Opener (Unit) that all parts of the Unit, other than remote controlled transmitters and accessories, globes and batteries, are free from defects in materials and workmanship for a period of 24 months from the date of purchase when installed in a residential premise with a residential specified gate that is designed for the sole purpose of domestic domicile. Chamberlain warrants that remote controlled transmitters and accessories included with the Unit are free from defects in materials and workmanship for a period of 12 months from the date of purchase.

Batteries and globes are not covered under the Chamberlain Limited Warranty.

It is a condition of this Chamberlain Limited Warranty that the Unit is sold, installed and serviced by a Professional Dealer appointed by Chamberlain. A Merlin® branded gate opener purchased over the internet and installed by a person other than a Professional Dealer will not be covered by this Chamberlain Limited Warranty.

During the applicable Chamberlain Limited Warranty period, if you are concerned that the Unit may be defective, for prompt on-site service call the Professional Dealer that sold/installed the opener, or our service centre on the toll free number below and a Chamberlain technician will diagnose the problem and arrange for this to be rectified. Once the problem has been diagnosed, subject to your rights under the Australian Consumer Law with respect to major failures, Chamberlain or its Professional Dealer will provide you with:

1. repairs to the Unit
or
2. a replacement Unit.

Repairs and replacement parts provided under this Chamberlain Limited Warranty are provided free of charge and are warranted for the remaining portion of the original warranty period.

This Chamberlain Limited Warranty provides benefits which are in addition to your other rights and remedies as a consumer.

Exclusions

If our service centre determines that a warranty claim has been made in respect of a failure or defect arising under or out of any exclusion detailed below such that the claim is not covered under this Chamberlain Limited Warranty, we may, subject to your other rights and remedies as a consumer, charge you a fee to repair, replace and/or return the Unit to you. This Chamberlain Limited Warranty does not cover any failure of, or defect in, the Unit due to:

- 1 non-compliance with the instructions regarding installation, operation, maintenance and testing of the Unit or of any product with which the Unit is used;
- 2 any attempt by a person other than a Professional Dealer to repair, dismantle, reinstall or move the Unit to another location once it has been installed;
- 3 tampering, neglect, abuse, wear and tear, accident, electrical storm, excessive use or conditions other than normal domestic use;
- 4 problems with, or relating to, the gate or gate hardware, including but not limited to the gate;

- 5 problems caused by electrical faults or replacement of batteries;
- 6 water or moisture ingress that causes corrosion or electrical malfunction;
- 7 corrosion caused by sea air if located near a waterway, beach etc;
- 8 fitment in a commercial operating application; or
- 9 solid panel gates installed in an unprotected wind affected location resulting in the gate not closing;
- 10 non use of cable provided for second gate arm connection.

NB: A General Purpose Outlet (GPO) ie: power point must be supplied by the consumer as this electrical fitting does not form a part of the Unit (opener). Excludes solar installations.

If this Chamberlain Limited Warranty does not apply, you may have rights available to you under the Australian Consumer Law.

Liability – Australia only

Except as set out in the Australian Consumer Law (being Schedule 2 of the Competition and Consumer Act 2010) (as amended, consolidated or replaced):

- 1 all other guarantees, warranties and representations in relation to the Unit or its supply are excluded to the extent that Chamberlain can lawfully exclude them; and
- 2 under no circumstances will Chamberlain be liable for consequential, incidental or special damages arising in connection with the use, or inability to use, the Unit, other than those which were reasonably foreseeable as liable to result from the failure.

Liability – New Zealand only

Except as set out in the Fair Trading Act 1986 and the Consumer Guarantees Act 1993 (as amended, consolidated or replaced):

- 1 all other guarantees, warranties and representations in relation to the Unit or its supply are excluded to the extent that Chamberlain can lawfully exclude them; and
- 2 under no circumstances will Chamberlain be liable for consequential, incidental or special damages arising in connection with the use, or inability to use, the Unit, other than those which were reasonably foreseeable as liable to result from the failure.

Note: We request that you retain your sales docket or invoice as proof-of-purchase and attach it to this manual to enable you to establish the date of purchase in the unlikely event of a warranty service being required. Chamberlain reserves the right to change the design and specifications of the Unit without prior notification. Some features or accessories of the Unit may not be available in certain markets or areas. Please check with your distributor.

Chamberlain service centre contact details

Australia

Phone toll free 1800 638 234
Fax toll free 1800 888 121
Chamberlain Australia Pty. Ltd.
PO BOX 1446
Lane Cove NSW 1595

New Zealand

Auckland phone 09 477 2823
Phone toll free 0800 653 667
Fax toll free 0800 653 663

Email: customerservice@chamberlainnz.com

Website: www.go-merlin.com

™ Trademark of The Chamberlain Group, Inc.

® Registered Trademark of The Chamberlain Group, Inc.

© 2012 Chamberlain Group, Inc